

OPERATION, PARTS AND SAFETY MANUAL



SIGNODE®

PNSC-2

PNEUMATIC COMBINATION STRAPPING TOOL

IMPORTANT!
DO NOT DESTROY

It is the customer's responsibility to have all operators and servicemen read and understand this manual.

Contact your local Signode representative for additional copies of this manual.

READ ALL INSTRUCTIONS BEFORE OPERATING THIS SIGNODE PRODUCT

SIGNODE • 3620 WEST LAKE AVENUE • GLENVIEW, ILLINOIS 60025 U.S.A.

! WARNING

READ THESE INSTRUCTIONS CAREFULLY. FAILURE TO FOLLOW THESE INSTRUCTIONS CAN RESULT IN SERIOUS PERSONAL INJURY.

STRAP BREAKAGE HAZARD

Improper operation of the tool or sharp corners on the load can result in strap breakage during tensioning, which could result in the following:

- ! A sudden loss of balance causing you to fall.**
- ! Both tool and strap flying violently towards your face.**

Failure to place the strap properly around the load or an unstable or shifted load could result in a sudden loss of strap tension during tensioning. This could result in a sudden loss of balance causing you to fall.

- ! If the load corners are sharp use edge protectors.**
- ! Positioning yourself in-line with the strap, during tensioning and sealing, can result in severe personal injury from flying strap or tool. When tensioning or sealing, position yourself to one side of the strap and keep all bystanders away.**

TRAINING

This tool must not be used by persons not properly trained in its use. Be certain that you receive proper training from your employer. If you have any questions contact your Signode Representative.

EYE INJURY HAZARD

Failure to wear safety glasses with side shields can result in severe eye injury or blindness. Always wear safety glasses with side shields which conform to ANSI Standard Z87.1 or EN 166.



FALL HAZARD

Maintaining improper footing and/or balance when operating the tool can cause you to fall. Do not use the tool when you are in an awkward position.

CUT HAZARD

Handling strap or sharp parts could result in cut hands or fingers. Wear protective gloves.



TOOL CARE

- ! Inspect and clean the tool daily. Replace all worn or broken parts.**
- ! Lubricate all moving parts weekly unless otherwise specified.**
- ! On air powered tools, always disconnect the pneumatic connection to the tool when performing part removal and replacement procedures. NEVER connect a pneumatic source to a disassembled tool unless otherwise specified.**

WORK AREAS

Keep work areas uncluttered and well lighted.

⚠ WARNING

READ THESE INSTRUCTIONS CAREFULLY. FAILURE TO FOLLOW THESE INSTRUCTIONS CAN RESULT IN SERIOUS PERSONAL INJURY.

Use correct Signode products for your application. If you need help contact your Signode Representative.

Signode tools and machines are designed and warranted to work together with Signode strapping and seals. Use of non-Signode strap and seals and/or manufactured or specified replacement parts may result in strap breakage or joint separation while applying strapping to a load or during normal shipping and handling. This could result in severe personal injury.

JOINT FORMATION

! Before using this tool, read its Operation and Safety instructions contained in this manual.

! This tool is a single reverse notch-joint sealers. Each notch-joint must be inspected to make certain it has two (2) good notches. A properly formed notch-joint will appear as shown in the illustration. If the notch-joint does not appear as shown, then the operator must proceed as follows.



1. Make certain that the tool's operating instructions are being followed before applying another strap.
2. Cut the strap off and apply a new strap and seal.
3. An improperly formed seal which does not have two (2) good notches, could result in strap separation. Before moving any package be certain that the seal is formed as shown. Inspect the joint to make certain it appears as shown in the illustration. If not, remove the broken strap and check the tool for worn or broken parts. Repair the tool for worn or broken parts. Repair the tool before applying another strap.

MOVING AND STACKING STRAPPED LOADS

Before moving or stacking any strapped load, follow all standard industry practices regarding safe material handling procedures.

CUTTING TENSIONED STRAP

Using claw hammers, crowbars, chisels, axes or similar tools will cause tensioned strap to fly apart with hazardous force. Use only cutters designed for cutting strap. Read the instructions in the cutter's manual for proper procedures in cutting strap. Before using any Signode product read its Operation and Safety Manual.

CLEANING & LUBRICATION

Clean and apply a light weight machine oil to all moving parts on a weekly basis. Clean the feedwheel daily with a wire brush. Debris accumulated in the teeth of either the feedwheel or the clutch plug must be removed with a small wire brush. A need to clean the teeth will become apparent when either the feedwheel skids on the strap or the lower strap slips on the clutch plug during tensioning. Refer to the Pneumatic Information shown in this manual for lubricant recommendations with regard to the air motor.

TABLE OF CONTENTS	Page
General Safety Information	2
Specifications	5
Major Components	5
Pneumatic Information	6
Operating Instructions	9
Part Removal & Replacement	11
Parts List	12
Troubleshooting	16
Maintenance	18
Declaration of Conformity	19

 WARNING

Signode tools and machines are designed and warranted to work together with Signode strapping and seals. Use of non-Signode strap and seals and/or manufactured or specified replacement parts may result in strap breakage or joint separation while applying strapping to a load or during normal shipping and handling. This could result in severe personal injury.

PNSC2-12
Part No. 422495

PNSC2-58
Part No. 422496

PNSC2-34
Part No. 422497

PNSC2-34 HIGH TENSION
Part No. 422881

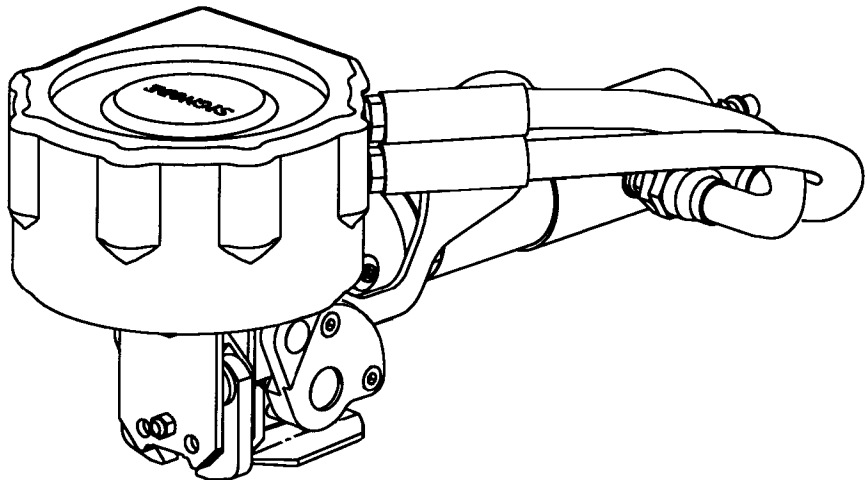

SPECIFICATIONS

MODEL	STRAP			SEALS
	TYPE	WIDTH	THICKNESS	
PNSC2-12	APEX & MAGNUS	1/2" (12.7mm)	.015" (.38mm) to .025" (.64mm)	12SPC
PNSC2-58		5/8" (15.8mm)		58SPC
PNSC2-34		3/4" (19mm)		34PNSC

MAJOR COMPONENTS

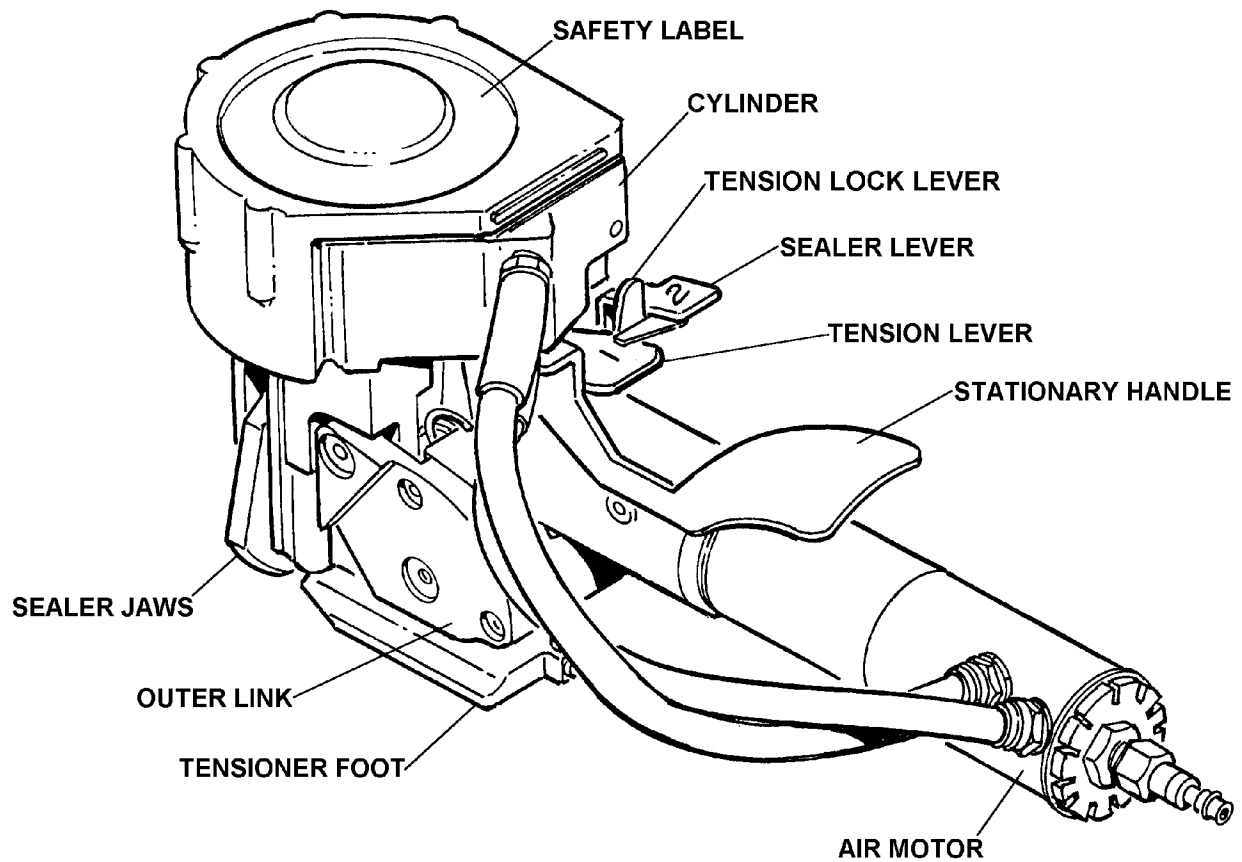

PNEUMATIC INFORMATION

AIR SUPPLY INSTALLATION

If compressor has a good dryer unit, use black pickled pipe. When a dryer unit is not installed, use galvanized or copper pipe.

To perform reliably, a pneumatic tool requires a continuous source of clean, water-free air at adequate pressure.

⚠ WARNING

- ! Never operate this tool using a bottled air or gas source.
- ! Bottled air/gas sources do not provide consistent operating pressure and could result in air pressures that exceed the maximum allowed for this tool.
- ! Exceeding the maximum allowable air pressure could result in severe personal injury.

A filter-regulator-lubricator unit (P/N 173111) must be installed as close to the air tool as possible, preferably within 10 feet (3M). It should be placed in a convenient location where it can easily be drained, adjusted, and filled with oil. The air hose (P/N 008558) must have at least a 3/8" (9.5mm) I.D. A quick-connect press-on socket (P/N 008569) is installed on the stress spring end of the hose for convenient hookup to the air tool.

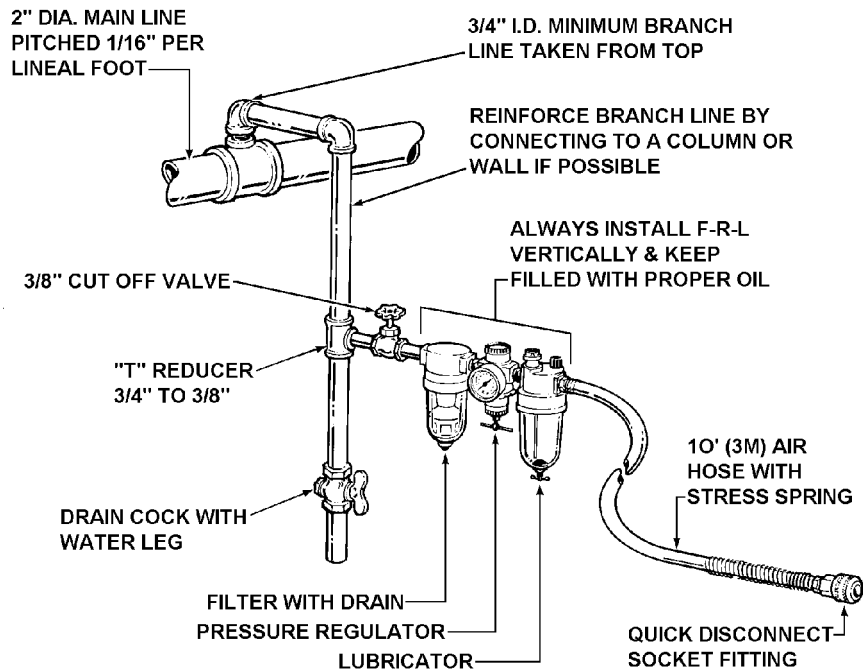

Filter and lubricator bowls are made of polycarbonate material. Do not install where bowls may be exposed to materials incompatible with polycarbonate. Certain oils, solvents, and chemicals or their fumes can weaken these bowls and possibly cause them to burst. Clean only with warm water. A cut-off valve placed ahead of the filter will be useful when cleaning the filter or replenishing the lubricator.

MOISTURE

Moisture is always present in air lines due to condensation within the lines as the air cools. Steps must be taken to remove this moisture and to keep it from the air tool. This is because water tends to wash away lubricants and cause corrosion, sticking and failure of internal parts.

The main line should be pitched so the far end terminates in a water leg. Branch lines are taken from the top of the main, never off the bottom. Every branch should have a water leg at its lowest point, with a drain cock which is drained daily.

If these precautions are taken and water is still present, an after cooler and a moisture separator are required between the compressor and the air receiver tank. A large air line separator can be installed in the air tool line, but precautions must be taken to insure that it will be drained daily, before the air tool is operated.

Water in air lines is a constant threat to the proper operation of air tools. Even near freezing operating conditions, a good refrigerant type dryer is essential. A good dryer will remove 95% or more of water right at the compressor. The remaining moisture is removed at the water leg in the piping system or in the filter, Signode Part No. 173111. Additional information is available in the Signode publication, "Air Supply Manual" Signode Part No. 186038. If you have any questions, contact your local Signode Representative.

LUBRICATION

The air motor must be properly lubricated. This is achieved by keeping the air line lubricator filled with oil and correctly adjusted. Without proper lubrication, the motor will become sticky and the tool will give low and erratic tension and be difficult to release from the strap.

Install the lubricator as close to the air tool as possible. The arrow on the lubricator's top surface must point in the direction of air flow.

For proper operation, oil must drop through the lubricator sight glass at a rate of 4 to 10 drops per minute. This rate is to be checked while the air tool is running free. Only 20% of this oil is actually delivered to the tool. The remaining oil drops back into the oil reservoir. The unit is factory set and should require no adjustment. If an adjustment is required, the adjusting screw on top of the lubricator may be turned as marked to reduce or increase the flow of oil.

The correct grade of oil must be used in the lubricator; too heavy an oil will not provide sufficient lubrication and will cause sticking and sluggish operation of the air tool.

Recommended oils are any good grade of rust and oxidation inhibiting oil with a viscosity of 80-120 S.U.S. at 100 degrees Fahrenheit. (0.15 to 0.25 cm² /sec. at 38 degrees Celsius), such as:

Non Fluid Oil Co., grade #LS-1236
Signode oil - Part No. 008556

If necessary, use SAE #5 or SAE #10, non-detergent, cut 1:1 with kerosene. Some oils contain anti-wear additives which may disable the air motor. Be certain to use recommended oil.

Several drops of lubricator oil added to the inlet of the air motor or into the air line each day will help insure good operation. A noticeable reduction of air motor performance can usually be corrected by squirting a few drops of oil into the air line.

PNEUMATIC INFORMATION, Continued

COLD WEATHER OPERATION

If a tool does not operate satisfactorily in freezing temperatures, certain steps can correct the problem. The following steps can be taken to improve cold weather operation of the tool:

- a. An air line dryer adjacent to the compressor.
- b. Use lubricant recommended by Signode. Signode has tested the use of anti-freezes, none work well in air tools; the tool will gum up when anti-freezes are introduced and will not function properly. The best lubricant for freezing weather is the 1 to 1 oil and kerosene combination.
- c. If possible, run the air supply line to a indoor located Filter-Regulator-Lubricator or relocate the F-L-R to a warmer operating area.

AIR CONSUMPTION

Air consumption in cubic feet per minute (cfm) for the PNSC-2 can be calculated as follows:

$$\text{cfm} = (a) \times (b) \times (0.23)$$

a = Number of straps applied per minute.

b = Number of seconds air motor is on per strap during tensioning, from start to finish sealing.

0.23 = PNSC-2 efficiency ratio.

Example calculation:

$$(a) \times (b) \times (0.23) = 4 \times 5 \times 0.23 = 4.6 \text{ cubic ft/min.}$$

Peak strapping load is 4 straps/minute, so a=4.

Air motor is on 5 seconds/strap, so b=5.

PNSC-2 efficiency ratio is 0.23.

Air pressure is assumed to be 90 psig with the recommended size and length of air hose. Volume of air at room temperature and sea level pressure, or so-called "free air" conditions. For more detailed information about air supply systems, refer to Signode manual Part No. 186038.

AIR LINE PRECAUTIONS

Strap tension is controlled by air pressure. Use the proper air line piping and lubrication as specified in this manual. Your air pressure gauge must be accurate, therefore, confirm its accuracy by comparing it to a calibrated master gauge.

WARNING

Strap breakage hazard. 3/4" (19mm) strap can break during tensioning if inlet air pressure to the tool exceeds 70 psig. Strap breakage can result in severe personal injury. Maximum operating pressure is 90 psig.

OPERATING INSTRUCTIONS

WARNING

- ! Wear safety glasses which conform to ANSI Standard Z87.1 or EN 166.
- ! Stand to one side of the strap while tensioning. Make sure all bystanders are clear before proceeding.
- ! Failure to follow the above could result in serious personal injury.

1. Thread strap once through seal. Continue to encircle the bundle and thread the lead end back through the seal as shown. Sharply bend approximately 2 1/2" (64mm) of the strap end back under the seal. Pull out any strap slack.

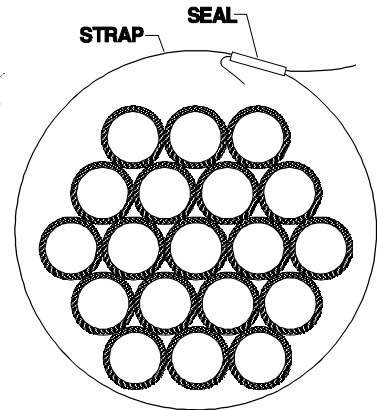
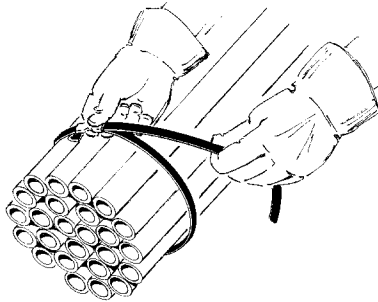
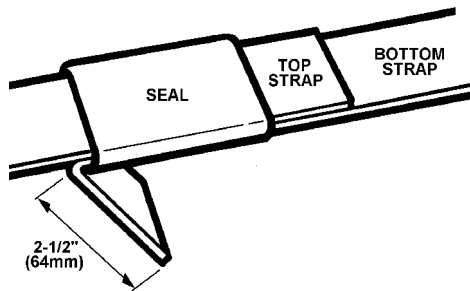

NOTE: A gentle upward bend on the top strap will hold the seal in place.

2. While holding the top strap with your left hand and with the tool in your right hand, squeeze the motor and stationary handle together to open up the strap path. Swing tool sideways to accept the top strap, making certain that the edge of the strap is in contact with the inside surface of the tensioner foot. While continuing to hold the motor against the stationary handle, slide the tool forward as far as possible.

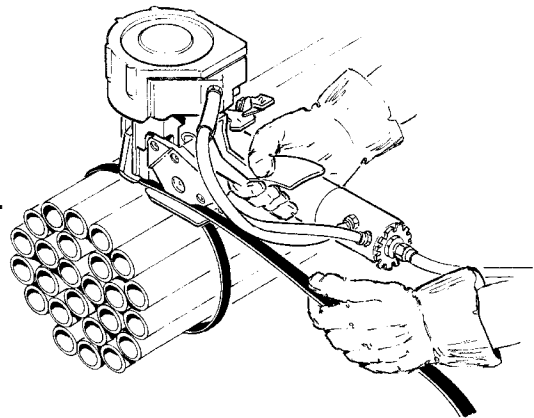

3. While continuing to hold the tool by the motor, release the stationary handle. Press the lever marked #1 to its locked position (tension) to begin tensioning the strap around the bundle. The tool will stall when the set tension level has been reached. If the tension is too much or too little, the tension can be adjusted as described elsewhere in this manual.

NOTE: If strap alignment on the package is unsatisfactory and it becomes necessary to shut off the tool during tensioning portion of the cycle, move the tension lock lever to the right to allow the tension lever to release and stop tensioning. Squeeze handle and motor together to release tool and realign strap.

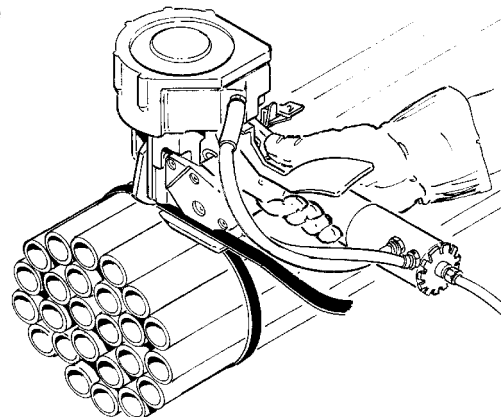

OPERATING INSTRUCTIONS, Continued

4. Press and momentarily hold the lever marked #2 (sealer) all the way down until the sealing and cut-off cycle has been completed. Hold onto tool as the sealer jaws will disengage freeing the tool from the strap.
5. Squeeze the stationary handle and motor together to release the cut off strap end. To make sure the tool has properly formed a joint, closely inspect the seal for two well formed notches - see Joint Inspection.

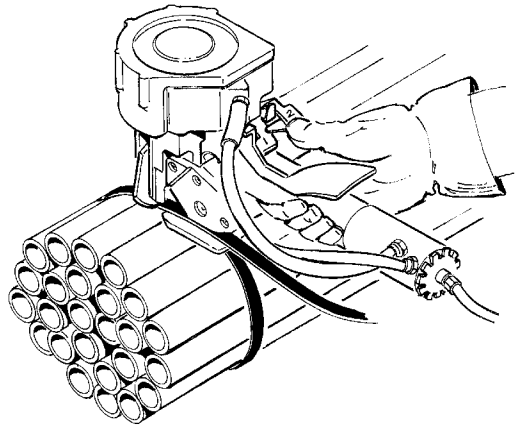

STRAP JOINT APPEARANCE & FORMATION

- ! Before using this tool, read its Operation and Safety instructions contained in this manual.
- ! This tool is a single reverse notch-joint sealers. Each notch-joint must be inspected to make certain it has two (2) good notches. A properly formed notch-joint will appear as shown in the illustration. If the notch-joint does not appear as shown, then the operator must proceed as follows.



1. Make certain that the tool's operating instructions are being followed before applying another strap.
2. Cut the strap off and apply a new strap and seal.
3. An improper formed seal which does not have two (2) good notches, could result in strap separation. Before moving any package be certain that the seal is formed as shown. Inspect the joint to make certain it appears as shown in the illustration. If not, remove the broken strap and check the tool for worn or broken parts. Repair the tool for worn or broken parts. Repair the tool before applying another strap.

! WARNING

NEVER HANDLE OR SHIP ANY LOAD WITH IMPROPERLY FORMED JOINTS. Misformed joints may not secure the load and could cause serious injury. Follow the joint inspection procedures in each sealer's manual.

PART REMOVAL, REPLACEMENT & ADJUSTMENTS

REFER TO PAGES 12, 13, 14 & 15 FOR ADDITIONAL INFORMATION

FEEDWHEEL & WEAR PAD

1. To replace the feedwheel (Pg13, #3), remove the two socket head cap screws (Pg13, #15) and lock washers (Pg13, #48) which secure the outer link (Pg13, #51).
2. Remove the outer link from the gear housing.
3. Slide the feedwheel off the feedwheel shaft.
4. The wear pad (Pg13, #22) can now be easily replaced. Simply press out the wear plug from the under side of the tool. Install the wear pad with a new o-ring (Pg13, #17) making sure the plug is solidly seated.
5. Replace the feedwheel and outer link.

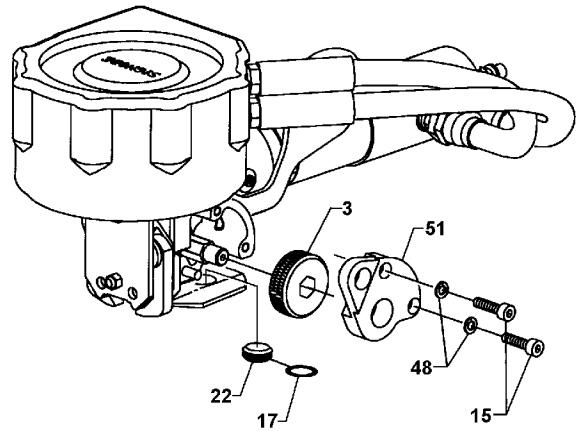

6. Check the feedwheel to wear pad clearance. The clearance between these parts should be .002" to .006" (0.05-0.15mm). Adjust the clearance as required by turning the M6 socket head set screw (Pg15, #14). Turning the adjustment screw clockwise increases the gap.

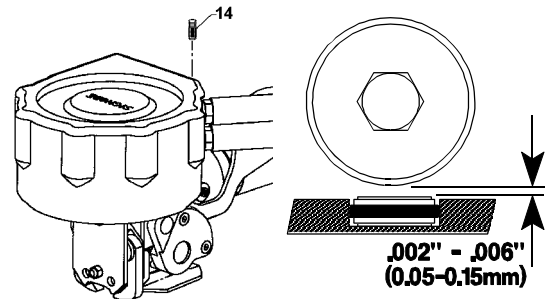

STRAP TENSION

Strap tension is controlled by air pressure. Use the proper air line piping and lubrication as specified in this manual. Your air pressure gauge must be accurate, therefore, confirm its accuracy by comparing it to a calibrated master gauge.

Adjust strap tension as follows:

1. Make sure the air pressure is set between 70 and 90 psig (4.8 - 6.2 bar).
2. Turn the adjustment valve screw (Pg15, #55) found on the underside of the air motor in 1/4 turn increments as required. Turn the screw clockwise to decrease tension and counterclockwise to increase tension.

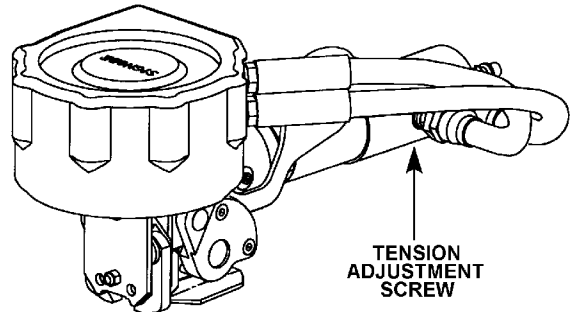

⚠ WARNING

Strap breakage hazard. 3/4" (19mm) strap can break during tensioning if inlet air pressure to the tool exceeds 90 psig. Strap breakage can result in severe personal injury. Maximum operating pressure is 90 psig.

Never remove the adjusting screw from the tool with the air connected. The screw could become a flying projectile.

PARTS LIST, TOOL

KEY	QTY	PART NO.	DESCRIPTION
1	1	422499	PNSC2 TENSION UNIT
2	1	422482	ENERGIZING SPRING
3	1	422472	FEED WHEEL
4	2	422801	AIR HOSE ASSEMBLY
5	1	422848	FOOT
6	1	422410	CYLINDER
7	1	020680	O-RING (#112)
8	2	422849	FLAT WASHER .625"OD x .320"ID x .020"
9	1	422477	PISTON
10	1	422837	M8 HEX LOCK NUT
11	1	023094	O-RING
12	1	422459	GASKET
13	1	422457	CYLINDER COVER
14	1	422460	PROTECTIVE COVER
15	15	011214	SHCS M5 x 16
16	1	422485	TENSION VALVE SPACER
17	4	092772	O-RING (#14)
18	1	422851	TENSION VALVE SPRING LC-032E-11
19	2	020701	O-RING .208"ID x .348OD" x .070"
20	1	422416	TENSION VALVE STEM
21	1	422415	TENSION VALVE SLEEVE
22	1	422487	WEAR PLUG
23	1	023043	VALVE SPRING
24	3	023046	SEAL
25	1	023042	SLEEVE SPACER
26	3	023040	VALVE SLEEVE
27	2	008596	O-RING (#111)
28	1	023041	VALVE STEM
29	1	422461	RAM
30	1	422462	RAM PIN
31	2	422844	JAW LINK (34)
	2	422842	JAW LINK (58,12)
32	1	306755	LOCK NUT M5 POLY INSERT
33	1	012905	FRONT PLATE (34)
	1	023030	FRONT PLATE (58)
	1	023062	FRONT PLATE (12)
34	2	306394	JAW (134)
	2	422832	JAW (58)
	2	422450	JAW (12)
35	2	023048	LINK PIN
36	2	306392	NOTCHER (34)
	2	023026	NOTCHER (58, 12)
37	1	023027	NOTCHER SPACER
38	2	023028	SIDE PLATE SPACER
39	1	012902	REAR PLATE (34)
	1	023031	REAR PLATE (58, 12)
40	2	023029	NOTCHER PIN
41	1	422839	FSHCS M5 x 25
42	2	422802	SEALER PIN
43	1	422803	KEEPER
44	2	422806	BUSHING GARLOCK 12mm ID x 4mm OD x 8mm LG
45	1	422856	φ4 x 20 LG TAPER PIN (DIN 1472)
46	1	422476	PIVOT SHAFT
47	1	422452	HANDLE
48	5	306079	LOCKWASHER M5
49	1	422809	BEARING TORRINGTON M-681, 3/8 ID x 9/16 OD x 1/2, CL-END
50	1	422805	BEARING, GARLOCK MB1008OU, 10MM ID x 12MM OD x 8MM
51	1	422469	OUTER LINK

KEY	QTY	PART NO.	DESCRIPTION
52	1	422464	CUTTER BLOCK
53	2	422804	SPRING LC-035C-6
54	1	422492	ANGLE CUTTER
55	2	422835	φ5 x 12 DOWEL PIN
56	1	433304	WARNING LABEL
57	1	422847	HANGER BRACKET
58	1	422854	M6 x 40 LG ROLL PIN (DIN 1481)
59	1	020913	O-RING
60	1	422858	DOUBLE SEAL O-RING, QUATTRO SEAL (#112)
61	1	251299	φ4 x 12 DOWEL PIN
62	1	274466	3MM HEX KEY
63	1	274467	4MM HEX KEY
64	1	422421	SET SCREW, M5 X 12

WARNING

Inspect all parts daily and replace them if they are worn or broken. Failure to do this can affect a product's operation and could result in serious personal injury.

OPTIONAL SIDE MOUNT HANGER (PART NUMBER 422404)

The PNSC-2 can be equipped with this optional side hanger for applications which require horizontal strapping.

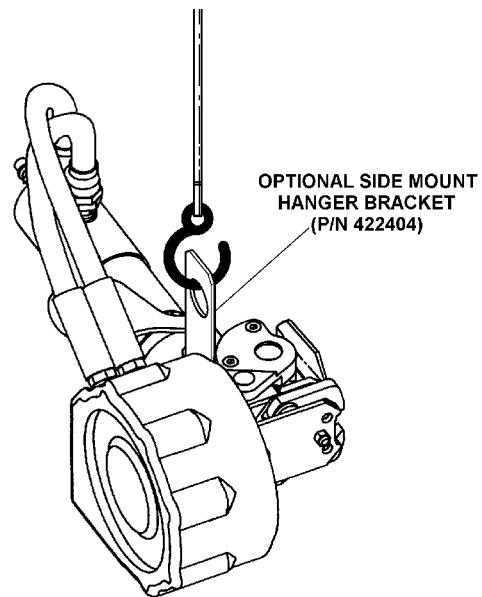

**LOOSE PACKAGED
ITEMS FOR PNSC-2**

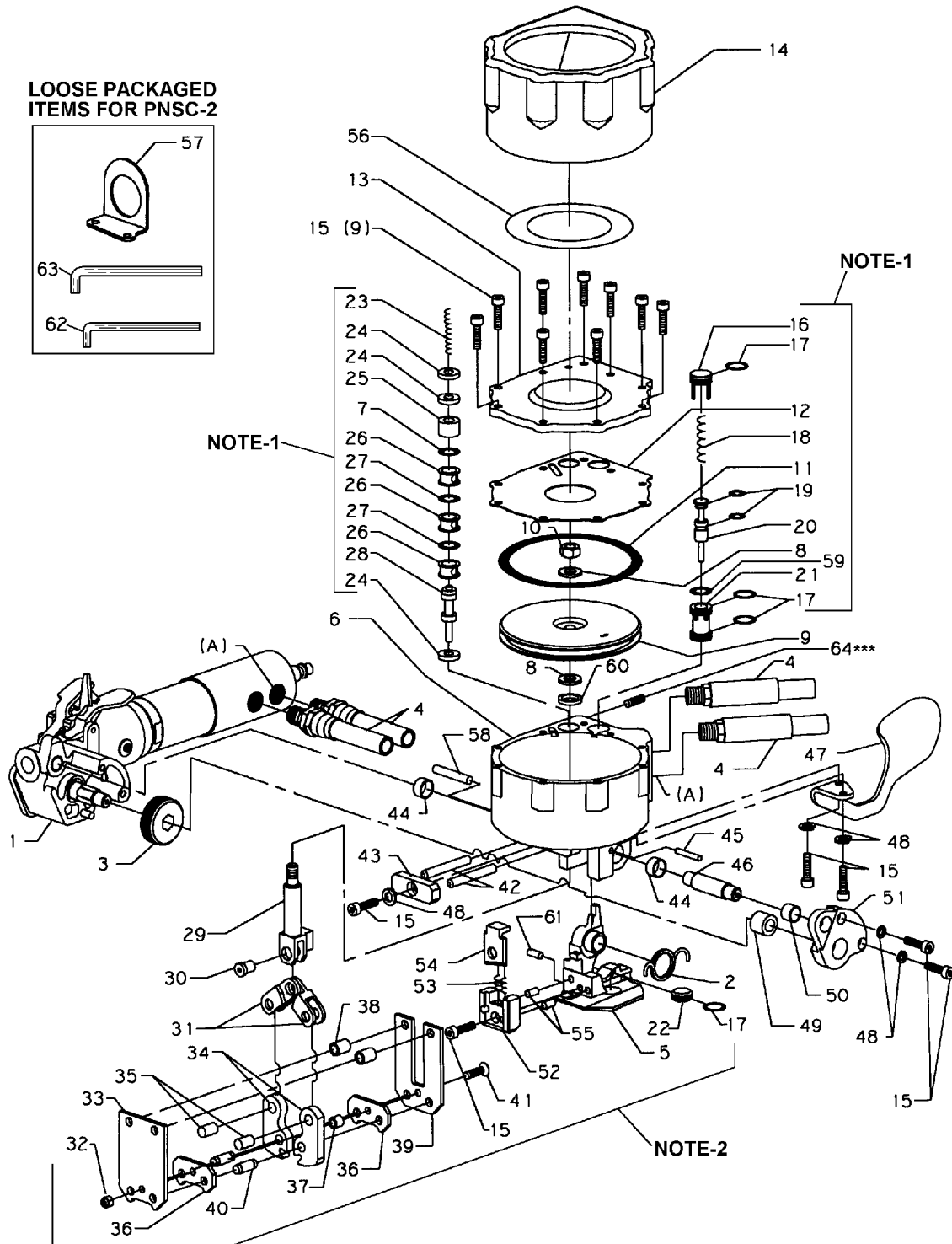
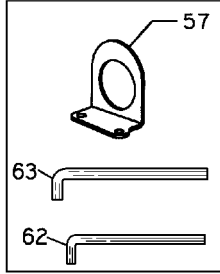

*** To be serviced only by an authorized Signode Service facility.

NOTES:

1. Reassemble the tension/sealing valve parts using White Lubriplate GR-132 grease (Signode P/N 422792 or equivalent).
2. Reassemble the sealer parts, pivot shaft, cutter and outer link using Black Lubriplate 3000W grease (Signode P/N 422793) or equivalent.

PARTS LIST, TENSION UNIT (422299 STD) (422868 HT)

KEY	QTY	TENSION UNIT	TENSION UNIT	DESCRIPTION
		422299	422868	
1	3	011214	011214	M5 x 16 SHCS
2	1	422470	422470	GEAR CASE COVER
3	1	422473	422473	GEAR CASE GASKET
4	1	023445	023445	BEARING FAFNIR S5K
5	1	023421	023421	WORM GEAR
6	1	023443	023443	BEARING
7	1	422455	422455	GEAR HOUSING
8	1	256791	256791	DOWEL PIN 0 5 x 14MM
9	1	422474	422474	FEED WHEEL SHAFT
10	1	008596	008596	O-RING
11	1	422827	422827	BEARING TORRINGTON JT-89
12	1	422805	422805	BEARING GARLOCK 1008D(J
13	1	422488	422488	RING GEAR LOCK SCREW
14	1	422843	422843	M6 x 16 SHSS
15	1	422486	422486	LOCK LEVER PIN
16	1	422838	422838	LEVER PIVOT PIN
17	1	022812	022812	SPRING LEE LC-026C-5
18	1	422483	422483	TENSION LEVER SPRING
19	1	422428	422428	TENSION LEVER
20	1	422484	422484	SEAL LEVER SPRING
21	1	422493	422493	TENSION LOCK LEVER
22	1	422429	422429	SEAL LEVER
23	1	422466	422466	RETAINING RING
24	1	008756	008756	BEARING FAFNIR 7203
25*	1	422826	422878	WORM ASSEMBLY
26*	3	422471	-	16T IDLER GEAR
	3	-	306436	17T IDLER GEAR
27	1	422481	422481	RING GEAR
28	1	008781	008781	SPACER
29	1	422825	422825	GEAR HOUSING
30	1	023551	023551	SEAL
31	1	422821	422821	MOTOR RING NUT
32	1	422823	422823	RETAINING RING
33	2	023481	023481	BEARING
34*	1	422833	422438	IDLER CARRIER ASSEMBLY
35	3	024607	024607	IDLER GEAR
36	1	024608	024608	RING GEAR
37	1	306612	306612	NEEDLE ROLLER
38	1	422822	422822	WASHER PLASTIC
39	2	014541	014541	BELLEVILLE WASHER
40	1	422819	422819	FRONT END PLATE
41	1	422815	422815	CYLINDER
42	1	024602	024602	SPACER
43	1	422817	422817	ROTOR
44	5	422818	422818	VANE
45	1	422814	422814	BACK END PLATE
46	1	024633	024633	BEARING
47	1	422816	422816	ALIGN PIN
48	1	422813	422813	MOTOR HOUSING
49*	1	422810	422866	DEFLECTOR
50	1	422824	422824	MUFFLER
51*	1	422811	422865	DEFLECTOR END
52	1	024631	024631	AIR MOTOR STRAINER
53	1	020704	020704	HANSON PLUG
54	1	020701	020701	O-RING
55	1	422812	422812	RESTRICTION VALVE
56	1	422834	422834	RING GEAR SPACER
57	1	422853	422853	O-RING (127)

HANSEN PLUG

When removing/connecting the Hansen plug, hold the air motor inlet fitting with one wrench and tighten the Hansen plug with another. If this is not done, one can loosen or over tighten the air motor housing, thus affecting tool performance.

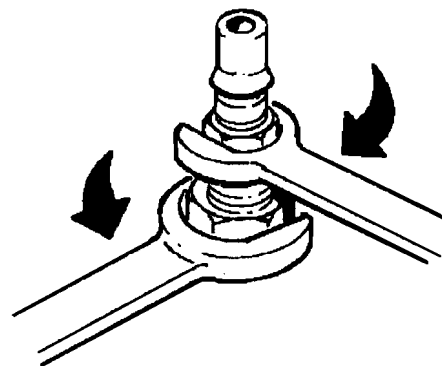

WARNING

Inspect all parts daily and replace them if they are worn or broken. Failure to do this can affect a product's operation and could result in serious personal injury.

* Items which are unique to each tension unit.

NOTE:

PACK GEAR HOUSING (KEY 7), IDLER GEARS, AND BEARINGS (EXCEPT KEY 49) WITH NON FLUID OIL K55 (NON FLUID COMPANY OR EQUIVALENT). GEAR HOUSING TO BE ABOUT 1/3 FULL. ALL OTHER MOTOR PARTS TO BE LUBED WITH AIR LINE OIL. VANES (KEY 47) MUST SOAK IN AIR LINE OIL OVERNIGHT BEFORE ASSEMBLY.

AIR MOTOR:

422830 (422299 STD)
422862 (422862 HT)

WASHERS TO BE PLACED BACK TO BACK WITH CUPPED SHAPE OUT) (

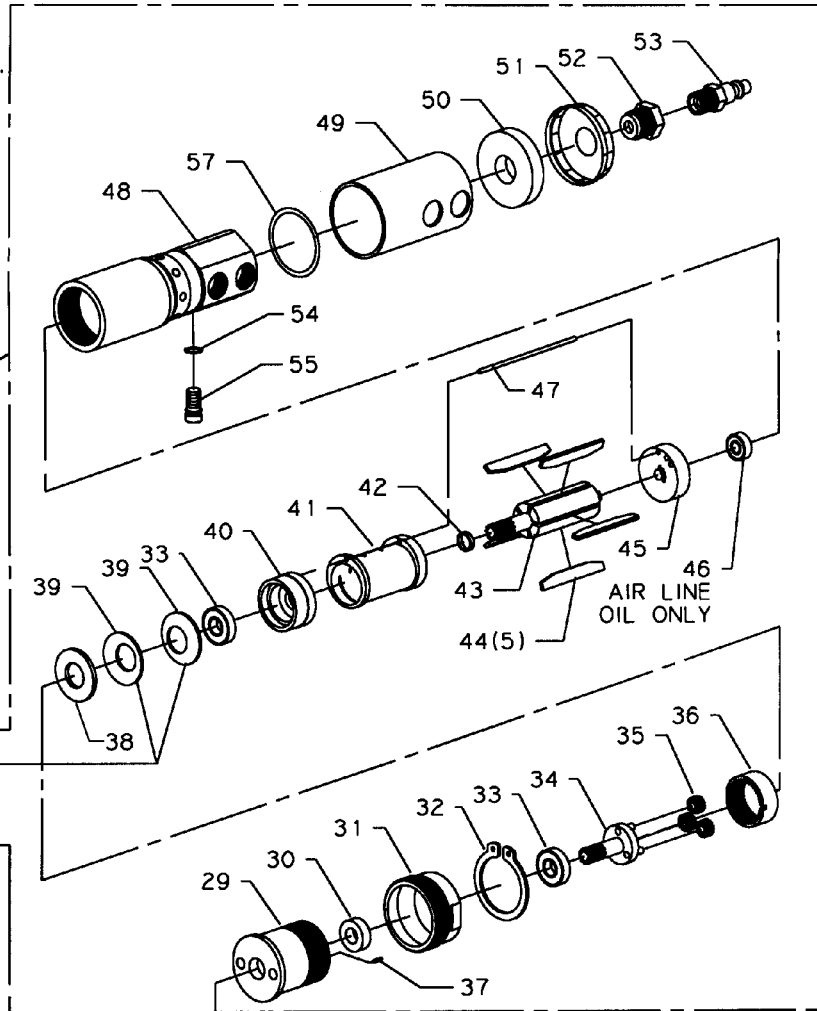

**** Use Loctite #242**

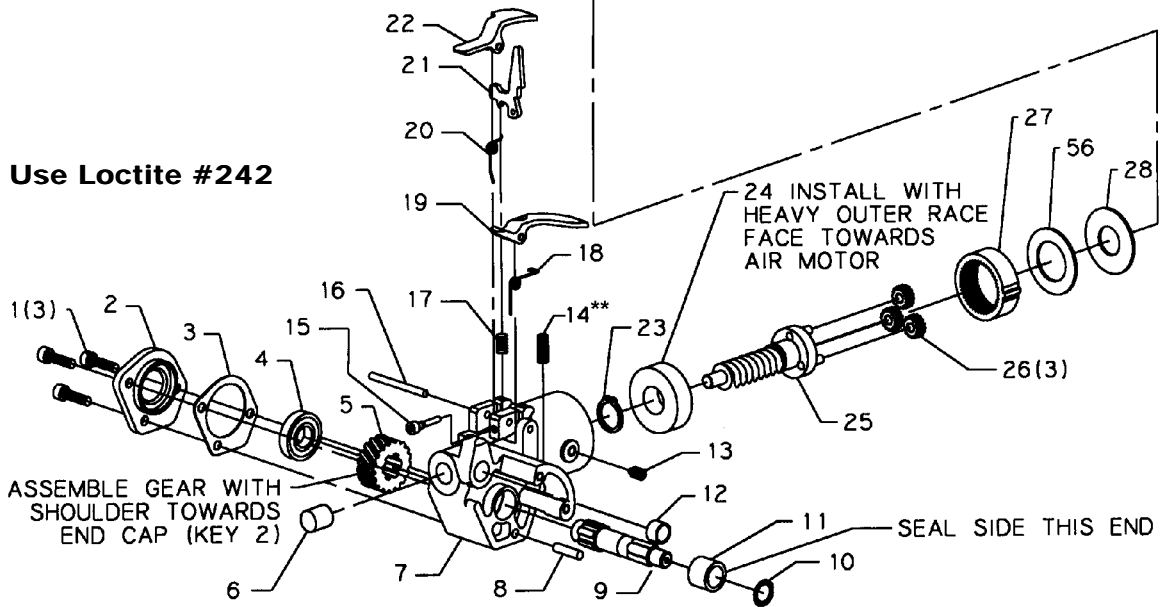

NOTES:

1. Key number 53 (Hanson Plug P/N 020704) is packaged loose with every new PNSC-2.
2. Air Motors (P/N 422830 & 422862) shown above can be ordered as a separate assembly from Signode Service.

TROUBLESHOOTING

The following items are the most common tool symptoms if problems occur. For symptoms or remedies not shown, contact your Signode service representative for additional information and details. The following tool symptoms are shown in this manual:

- #1 - Tool runs sluggishly.
- #2 - Filter-regulator-lubricator is maintained but still runs sluggishly
- #3 - Motor does not pick up speed when oiled.
- #4 - Air motor continues to run after sealing/cut-off cycle is completed.
- #5 - Low joint strength.
- #6 - Sealer valve sticks or leaks.
- #7 - Tool will not cut off strap.
- #8 - Feedwheel milling on strap.
- #9 - Seal pulls open during tensioning.

#1 SYMPTOM: The tool runs sluggishly.	
CAUSE	REMEDY
1. The air filter-regulator -lubricator is malfunctioning and is not properly maintained.	<ol style="list-style-type: none"> 1. Check the regulator to see that the correct air pressure is getting to the tool. 2. Check to see the filter unit is clean and functioning properly. 3. Examine the lubricator to see there is oil in the bowl and that the oil is seen dripping from the sight dome as the tool operates. This assures the air motor is being properly lubricated.

#2 SYMPTOM: The filter-regulator lubricator is properly maintained but the tool still runs sluggishly.	
CAUSE	REMEDY
The motor is dry, hindering it from providing maximum performance.	Pour a teaspoon of oil into the motor through the air inlet, hook the tool up to air and run it. An increase of speed indicates the motor was dry.

#3 SYMPTOM: The motor does not pick up speed with the addition of oil.	
CAUSE	REMEDY
The tool may run sluggishly due to clogged or dirty motor filter screen due to a lack of properly filtered air supply.	Remove the Hansen plug at the inlet to the air motor and examine the filter screen in the air strainer and clean it if necessary. See instructions on installing the Hansen plug.

#4 SYMPTOM: Air motor continues to run after sealing/cut-off cycle is completed.	
CAUSE	REMEDY
Excessive air line pressure.	Install Filter-Regulator-Lubricator near tool. Reduce air pressure to 90 psi (6.2 bar) maximum.

#5 SYMPTOM: Low joint strength.	
CAUSE	REMEDY
Worn jaws, notchers and pins in jaw stack.	Disassemble jaw stack and replace worn parts as required.

#6 SYMPTOM: Sealer valve sticks or leaks.	
CAUSE	REMEDY
<ol style="list-style-type: none"> 1. Dirt in sealer valve assembly. 2. O-Rings and seals in valve stem are worn or defective. 	<ol style="list-style-type: none"> 1. Disassemble and clean valve assembly. 2. Disassemble and replace O rings and seal as required.

#7 SYMPTOM: Tool will not cut off strap.	
CAUSE	REMEDY
<ol style="list-style-type: none"> 1. Lead edge on breaker foot worn. Inadequate air pressure. 2. Excessive pressure drop due to air line supply restrictions. 3. Worn cutter. 	<ol style="list-style-type: none"> 1. Replace breaker foot. Increase air pressure to 90 psi (6.2 bar) maximum. 2. Use 3/8" I.D. hose of minimum length. 3. Replace cutter.

#8 SYMPTOM: Feedwheel milling on strap.	
CAUSE	REMEDY
<ol style="list-style-type: none"> 1. Feedwheel is clogged with dirt. 2. Feedwheel is worn or has chipped teeth. 	<ol style="list-style-type: none"> 1. Clean teeth on feedwheel with wire brush (P/N 269589). 2. Replace feedwheel.

#9 SYMPTOM: Seal pulls open during tensioning.	
CAUSE	REMEDY
Tool is pulling excessive tension.	Lower the strap tension by turning the valve screw (Key 55 on page 15) clockwise. Note, do not turn the strap tension screw more than one rotation at a time without testing tool.

TOOL MAINTENANCE

The most common reason for poor tool performance and incorrectly formed straps joints is improper tool maintenance. The easiest way to determine if a tool is performing correctly is by inspecting the strap joint. Having a tool maintenance program is a simple task which consists of three parts. First, a quick daily inspection of the tool for any worn or broken parts. Secondly, keep each tool on a schedule of service intervals for cleaning and lubrication. Third, when problems do occur, use the troubleshooting guide to properly determine and fix problems before they lead to more serious tool conditions. Each of these three tasks have been outlined for this particular tool, read and understand all information for improving the life and performance of the tool.

TOOL INSPECTION

Visually inspect the exterior of the tool on a daily basis. Decreased tool life can be prevented by early detection of broken parts. Replace all broken parts with new parts. Review the Parts Removal, Replacement & Adjustments portion of this manual for information and details.

SERVICE INTERVALS

This tool, like most Signode tools, can be used with various sizes of strap which cause different rates of component wear. Also, wear is affected by the environment and tension that the tool applies. In the worst case, heavy gauge wide strapping. All critical moving components of the tool should be inspected at particular intervals, some more often than others. Broken parts can decrease sealing effort, leading to additional component wear and produce lower joint strength.

Inspect the components of the sealing mechanism when:

- A. Joint does not appear as shown in this manual or visually it is detected that the joint is not all formed or formed improperly.
- B. Sealing effort requires higher air pressure or tool is difficult to remove from strap.
- C. When scheduled.

 DANGER If there is any question that joint formation is not as shown or is suspect, it is important that you contact your tool representative immediately.

The feed wheel and wear plug are also subject to wear and chipping. A daily cleaning of these parts by brushing off debris will be important to maintaining long life. The first indication of wear will be strap slippage during tensioning. The operator of the tool should be instructed on how to determine when the strap slips during tensioning. Sometimes the teeth need to be cleaned with a wire brush, but if slipping is allowed to continue, the parts will need to be replaced. Using the tool in a dirty environment will increase feedwheel wear.

NOTE: On some Signode tools the feedwheel can be cleaned by holding the tool open in the strap loading position while the tool runs without strap and using a wire brush to clean the feedwheel as it rotates.

Inspect the components of the tensioner mechanism when:

- A. Strap slips when being tensioned.
- B. Evidence of feedwheel milling on the strap face.
- C. When scheduled.

TOOL LUBRICATION

Signode tools use a variety of greases and oils, all of which can be ordered through Signode. When ordering indicate tool model, part number and name.

■ SIGNODE®

EU Declaration of Conformity

The Supply of Machinery (safety) Regulations
1992 (S.I. 1992/3073)

It is hereby declared that the undermentioned machinery has been designed and constructed to comply with the health and safety requirements defined in EC Directive 89/392/EEC

Machine Supplier: Signode, Division of ITW Ltd.
Queensway, Fforestfach
Swansea SA5 4ED

Machine Description: PNSC-2 Series

Machine Type: Pneumatic Combination Hand Strapping tool.

Provisions with which machine complies:

89/392/EEC, 91/368/EEC

Harmonized EuroNorms with which machine complies:

EN 292:1, EN 292:2, EN 294, EN 349

Technical Standards with which machine complies:

NA

Signature: 
(Peter Oseland)

Date: 2 DEC 1996

SIGNODE NEW TOOL WARRANTY

Signode Engineered Products Warrants that a new Signode strapping tool will operate per functional specifications for a period of sixty (60) days after the date of shipment to the owner's place of business. Normal wearing parts, as outlined in the Operation, Parts & Safety manual, are covered by a thirty (30) day warranty unless, in Signode's judgement, these parts have been subjected to abnormal or extreme usage. Signode's sole liability hereunder will be to repair or replace, without charge, F.O.B. Signode's Glenview, Illinois plant, any tool which proves to not operate per functional specifications within the stated period. Signode reserves the right to replace any tool which proves not to operate per functional specifications with a new or like-new tool of the same model if in Signode's judgement such replacement is appropriate. Any new replacement tool provided to an owner will carry a full sixty (60) day warranty. Any warranty repaired tool or like-new replacement tool will carry a warranty for the balance of the time remaining on the initial sixty (60) day warranty. This warranty will be extended to compensate for the time the tool is in Signode's possession for warranty repairs.

This warranty is void as to any tool which has been: (I) subjected to mis-use, misapplication, accident, damage, or repaired with other than genuine Signode replacement parts, (II) improperly maintained, or adjusted, or damaged in transit or handling; (III) used with improperly filtered, unlubricated air or improper strapping material, (IV) in Signode's opinion, altered or repaired in a way that affects or detracts from the performance of the tool.

SIGNODE MAKES NO WARRANTY, EXPRESSED OR IMPLIED, RELATING TO MERCHANTABILITY, FITNESS OR OTHERWISE EXCEPT AS STATED ABOVE AND SIGNODE'S LIABILITY AS ASSUMED ABOVE IS IN LIEU OF ALL OTHERS ARISING OUT OF OR IN CONNECTION WITH THE USE AND PERFORMANCE OF THE TOOL. IT IS EXPRESSLY UNDERSTOOD THAT SIGNODE SHALL IN NO EVENT BE LIABLE FOR ANY INDIRECT OR CONSEQUENTIAL DAMAGES INCLUDING, BUT NOT LIMITED TO, DAMAGES WHICH MAY ARISE FROM LOSS OF ANTICIPATED PROFITS OR PRODUCTION, SPOILAGE OF MATERIALS, INCREASED COSTS OF OPERATION OR OTHERWISE.

Considerable effort has been made to ensure that this product conforms to our high quality standards. However, should you experience any difficulties, please contact your Sales Representative providing samples and the manufacturing code specified on the tool.

Thank you for your help.

SIGNODE ENGINEERED PRODUCTS
Hand Tool Division
3620 W. Lake Avenue, Glenview, Illinois 60025

PART #	DESCRIPTION	AREA OF USE
LUBRICANTS		
177029	GEAR HOUSING GREASE	CLUTCH DRIVES, INTERNAL GEARS, GEAR SETS
422792	WHITE LUBRIPLATE GR-132 GREASE	PNEUMATIC PARTS, AIR CYLINDERS, AIR VALVES, O-RINGS
422793	BLACK LUBRIPLATE 3000W GREASE	MOVING INTERNAL PARTS, JAWS, LINKS
432322	EP ACCROLUBE GREASE	HIGH FRICTION CONTACT PARTS
008556	LS-1236 AIR LINE OIL	AIR MOTORS, AIR VALVES
ADHESIVES		
422794	LOCTITE #222, PURPLE	LOW STRENGTH, SCREWS 1/4" (6MM) OR SMALLER SIZES
422795	LOCTITE #242, BLUE	MEDIUM STRENGTH, SCREWS 5/16" (8MM) OR LARGER SIZES
422796	LOCTITE #271, RED	HIGH STRENGTH, SEMI-PERMANENT SCREW APPLICATION
422797	LOCTITE #609, GREEN	PERMANENT, CURVED SURFACE PART CONTACT
274111	LOCTITE #380, BLACK MAX	PERMANENT, FLAT SURFACE PART CONTACT
CLEANING BRUSHES		
023963	SMALL BRUSH	FEEDWHEEL & GRIPPER TEETH
269589	LARGE BRUSH	FEEDWHEEL & GRIPPER TEETH