

# OPERATION, PARTS AND SAFETY MANUAL



# **SIGNODE®**

## AST

### COMBINATION STRAPPING TOOL

**IMPORTANT!  
DO NOT DESTROY**

It is the customer's responsibility to have all operators and servicemen read and understand this manual.

Contact your local Signode representative for additional copies of this manual.

***READ ALL INSTRUCTIONS BEFORE OPERATING THIS SIGNODE PRODUCT***

---

**SIGNODE • 3620 WEST LAKE AVENUE • GLENVIEW, ILLINOIS 60025 U.S.A.**

---

# **WARNING**

**READ THESE INSTRUCTIONS CAREFULLY. FAILURE TO FOLLOW THESE INSTRUCTIONS CAN RESULT IN SEVERE PERSONAL INJURY.**

## **GENERAL SAFETY CONSIDERATIONS**

### **1. STRAP BREAKAGE HAZARD.**

Improper operation of the tool or sharp corners on the load can result in strap breakage during tensioning, which could result in the following:

- A sudden loss of balance causing you to fall.
- Both tool and strap flying violently towards your face.

Failure to place the strap properly around the load or an unstable or shifted load could result in a sudden loss of strap tension during tensioning. This could result in a sudden loss of balance causing you to fall.

Read the tool's operating instructions. If the load corners are sharp use edge protectors. Place the strap correctly around a properly positioned load.

- Positioning yourself in-line with the strap, during tensioning and sealing, can result in severe personal injury from flying strap or tool. When tensioning or sealing, position yourself to one side of the strap and keep all bystanders away.

### **2. TRAINING.**

This tool must not be used by persons not properly trained in its use. Be certain that you receive proper training from your employer. If you have any questions contact your Signode Representative.

### **3. EYE INJURY HAZARD.**

Failure to wear safety glasses with side shields can result in severe eye injury or blindness. Always wear safety glasses with side shields which conform to ANSI Standard Z87.1 or EN 166.



### **4. FALL HAZARD.**

Maintaining improper footing and/or balance when operating the tool can cause you to fall. Do not use the tool when you are in an awkward position.

### **5. CUT HAZARD.**

Handling strap or sharp parts could result in cut hands or fingers. Wear protective gloves.



# **! WARNING**

## **6. TOOL CARE.**

Take good care of the tool. Inspect and clean it daily, lubricate it weekly and adjust when necessary. Replace any worn or broken parts.

## **7. WORK AREA.**

Keep work areas uncluttered and well lighted.

Use the correct Signode products for your application. If you need help contact your Signode Representative.

## **SAFETY PROCEDURES FOR TOOL OPERATION**

### **1. OPERATION SEQUENCE.**

Before using this tool, read its Operation and Safety Instructions contained in this manual.

2. This tool is a crimp type sealer. A properly formed joint will appear as shown in the illustration. If the joint does not appear as shown, then the operator must proceed as follows:

- A. Ensure that the tool's operating instructions are being followed before applying another strap.
- B. Cut the strap off and apply another.

If the joint still does not appear as shown, then inspect the tool for worn and/or damaged parts. Replace tool parts as needed. **NEVER HANDLE OR SHIP ANY LOAD WITH IMPROPERLY CRIMPED JOINTS.** Miscrimped joints may not secure the load and could cause serious injury.

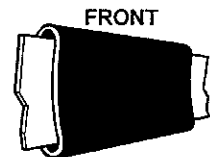
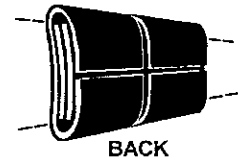

3. Tuck strap end back into the dispenser when not in use.

## **CUTTING TENSIONED STRAP**

Using claw hammers, crowbars, chisels, axes or similar tools can cause tensioned strap to fly apart with hazardous force. Use only cutters designed for cutting strap. Read the instructions in the cutter's manual for proper procedure in cutting strap. Before using any Signode product read its Operation and Safety Manual.

TABLE OF CONTENTS	PAGE
General Safety Instructions	2
Introduction	4
Major Component Identification	5
Specifications	5
Operating Instructions	6
Loading Seals	6
Strapping Cycle	6
Parts Replacement	8
Cutter Adjustment	8
Cleaning and Lubrication	8
Parts List	9

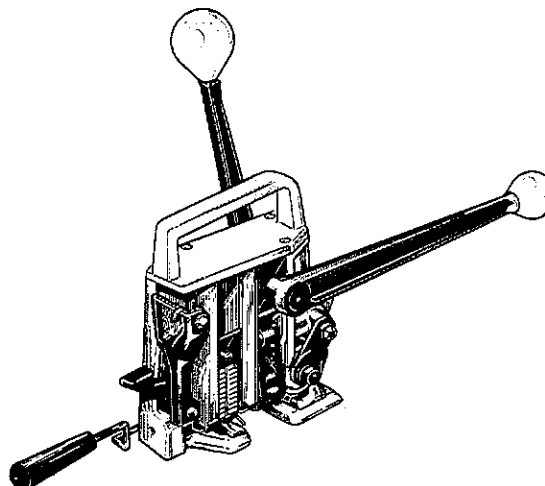

**AST Combination Tool**  
Part Number 422950

## INTRODUCTION

The AST is a manually operated hand tool that provides consistent tension and sealing. Once the strap has been placed around the package, the operator places both layers of strap within the tool, engages the feed wheel and tensions the strap. Using seals contained in the tool's magazine, the strap is then sealed together and cut free of the supply.

This manual provides information necessary for the safe operation of the AST hand tool and lists all the parts, complete with exploded views, in the event maintenance is indicated. Therefore, it is valuable and should be saved.

## **CAUTION**

Most of the fasteners in this product are metric. Before removing and replacing any part, refer to the parts listing to determine the proper tools to use and the correct size hardware that may have to be replaced.

## MAJOR COMPONENTS

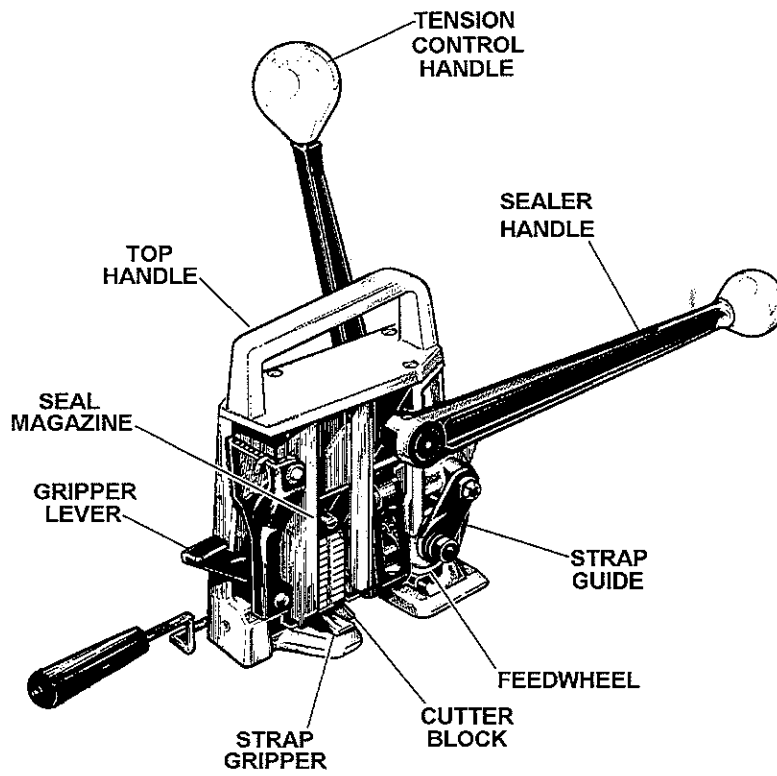

## SPECIFICATIONS

TOOL MODEL	SEAL	STRAP	
		CONTRAX	TENAX
AST	50-ASD	814, 816, 818	1816, 1818, 1822

# OPERATING INSTRUCTIONS

## LOADING SEALS

To load seals, raise the Seal Pad Assembly (69) and insert a stack of seals through the opening in the side of the Seal Magazine. Make sure the seal stack is properly seated on the Cutter Block (66).

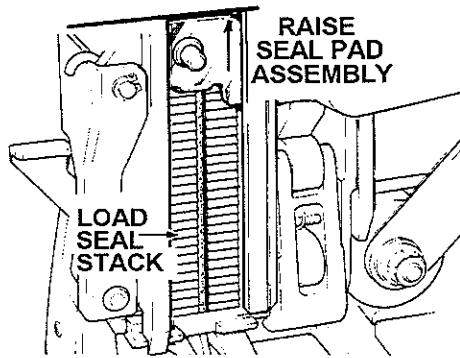

2. Encircle the package with the strap. Depress and hold the Gripper Lever (60). Insert the bottom strap lead under the Feedwheel (26) beyond the Strap Guide (40). Release the gripper Lever (60) to hold the bottom strap in place.

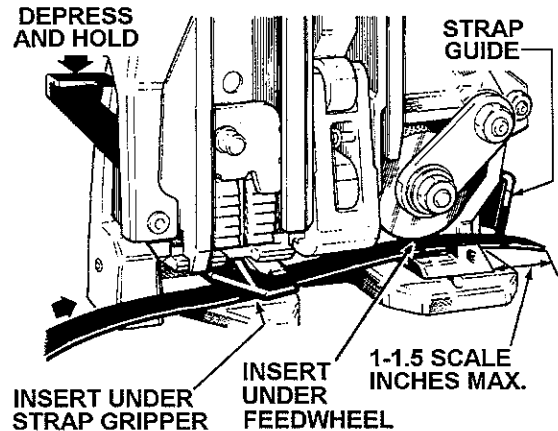

## STRAPPING CYCLE

**⚠ WARNING**

**WEAR SAFETY GLASSES**

Stand to one side of the strap while tensioning. Make sure all bystanders are clear before proceeding.

1. Push the Tension Handel (5) forward to its detent position. This will raise the Feedwheel (26) for strap insertion.

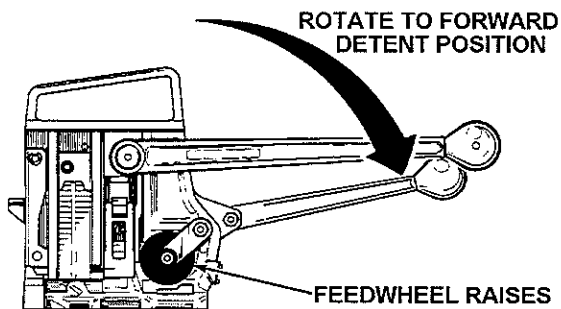

3. Insert the top strap beneath the Feedwheel (26) and into the strap slot of the Cutter Block (66). Pull excess slack from the strap.

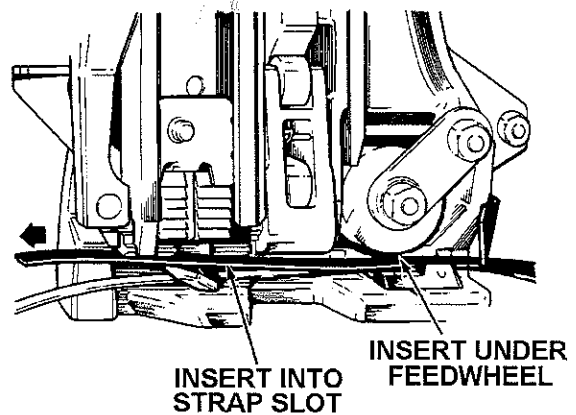

4. Hold tool by the Top Handle (1), move the Tension Control Handle (5) toward the operator to lower the Feedwheel (26). While standing to one side of the strap line, continue pulling Tension Handle to the rear to apply tension to the strap.

Return the Tension Handle (5) forward and repeat the action until the desired tension has been reached.

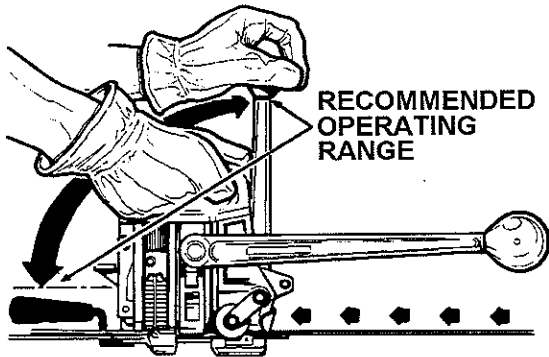

The Sealer Handle (76) is then returned to the forward stop position, which will raise the sealing mechanism and feed a new seal into the jaws.

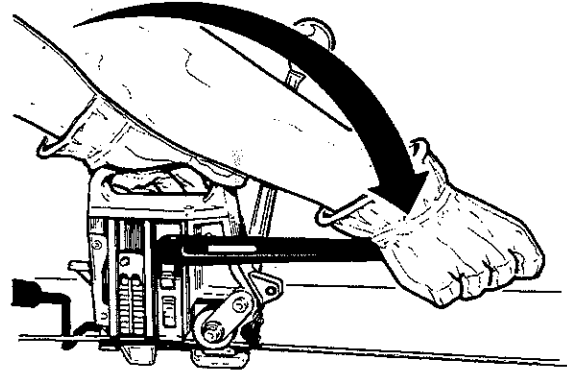

## **⚠ WARNING**

Do not rotate the tension handle too far forward as a sudden release of tension could occur. The above illustration shows the tension handle in its recommended furthest forward position.

- To remove the tool from the strap, return the Tension Handle (5) to the forward detent position, hold the tool by the Top Handle (1) and Rear Handle (47) swing the rear of the tool to the operator's left until it is free of the strap. Inspect the seal to make sure a proper joint has been formed. Refer to the Sealing Operation view for details.

- After the desired tension is reached, complete the sealing cutoff operation by pulling the Sealer Handle (76) to the rear stop position.

TO SEAL AND CUT-OFF,  
PULL SEALER HANDLE  
TO REAR STOP  
POSITION

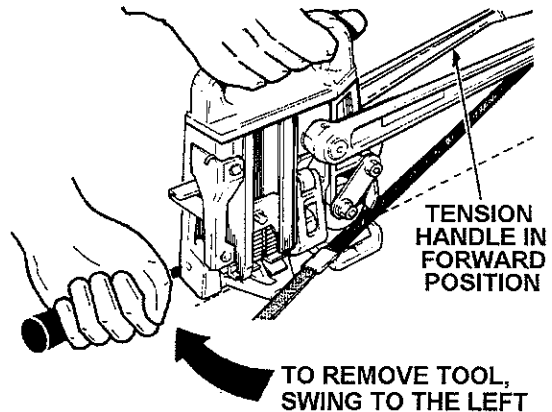
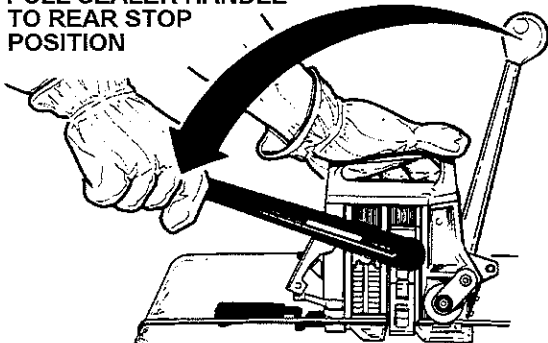

## SEALING OPERATION

This tool is a crimp type sealer. A properly formed joint will appear as shown in the illustration. If the joint does not appear as shown, the operator must proceed as follows:

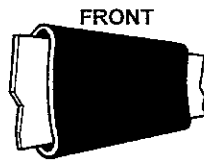
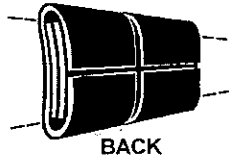

- A. Ensure that the tool's operating instructions are being followed before applying another strap.
- B. Cut the strap off and apply another.

If the joint still does not appear as shown, then inspect the tool for worn and/or damaged parts. Replace tool parts as needed. **NEVER HANDLE OR SHIP ANY LOAD WITH IMPROPERLY CRIMPED JOINTS.** Miscrimped joints may not secure the load and could cause serious injury.

## PARTS REPLACEMENT

To replace the Strap Gripper (59), Cutter Block (66), Magazine Spring (71), Cutter Blade (85), Retaining Clip Spring (96) or any part of the sealing mechanism, remove the three Socket Head Cap Screws (2), Top Handle (1), Socket Head Shoulder Bolt (62), and Socket Head Cap Screw (63).

Tilt the top of the Magazine at the back of the tool and pull out. Lift out the Sealing Mechanism. When installing the Magazine, the sealing mechanism must be in the raised position and the Roller Guide (86) properly located.

To replace the Feedwheel (26), remove the Locknut (13) on the Support Shaft (17), Hex Nut Left Hand (22), Washer (23) and Outer link (25) and pull out the Feedwheel (26).

To replace the Gripper Plug (44), remove the bottom two Socket Screws (43), Side Guide (42) and Pivot Pin (45) and push the Gripper Plug (44) upward.

## CUTTER ADJUSTMENT

If the Cutter on the tool does not cut strap properly, Loosen the Socket Head Cap Screw (62 and 63) and place the Sealing Handle in vertical position. Adjust the set screw (39) to take up clearance between the Cutter Blade (85) and the Cutter Block (66). The Sealer Mechanism must not bind after adjustment. Retighten Socket Head Cap Screws (62 and 63).

## CLEANING AND LUBRICATION

Clean teeth of Feedwheel (26) and Gripper Plug (44) with the brush (part no. 023963) provided with the tool.

Tools should be kept clean and all moving parts should be lubricated with light machine oil weekly.



## PARTS LIST

<u>KEY</u>	<u>QTY.</u>	<u>PART NO.</u>	<u>DESCRIPTION</u>
1	1	422970	TOP HANDLE
2	3	011214	SOCKET HD CAP SCREW M5X16
3	2	010057	ROLL PIN 1/4 DIA. X 1 3/4
4	2	010054	KNOB
5	1	422956	TENSIONER HANDLE
6	1	005164	DETENT PLUNGER
7	1	005165	DETENT SPRING
8	1	005279	DETENT BUSHING
9	1	007707	DETENT WASHER
10	1	423331	SEALER HANDLE ASSEMBLY (COMPLETE)
11	1	005185	TENSIONER PAWL
12	1	005186	PAWL SPRING
13	4	005211	LOCKNUT - 5/16-18
14	1	422978	HANDLE BUSHING
15	1	422976	ENERGIZING SPRING
16	1	422953	TENSIONER PINION
17	1	422962	PIVOT SHAFT
18	1	422957	HOLDING PAWL
19	1	005191	PAWL SPRING
20	1	005192	PAWL PIN
21	1	001611	COTTER PIN, 3/32 X 3/4
22	1	005209	HEX NUT L.H. 5/16-24
23	2	005208	WASHER
24	1	010160	BUSHING
25	1	010117	OUTER LINK
26	1	010116	FEEDWHEEL
27	1	422959	FEEDWHEEL SHAFT
28	1	422968	CAST BRONZE BRG. .500 X .625 X 1.000
29	1	422955	GEAR HOUSING
30	1	422954	TENSIONER GEAR
31	1	422965	CAST BRONZE BRG .375 X .625 X .500
32	1	160330	DOWEL PIN 10MM X 30
33	1	010134	ROLLER
34	1	023244	DETENT STOP
35	1	003911	LOCK NUT 5/16-24
36	1	086190	TRUARC, KLIPRING #5304-37
37	1	007453	FLAT WASHER 3/8 X 3/4 X .060
38	2	422971	CAST BRONZE BUSHING .375 X .562 X .250
39	1	422966	SOCKET SET SCREW M8 X 16, FLAT POINT
40	1	010135	STRAP GUIDE
41	1	063159	DOWEL PIN .250 X .500
42	1	010124	SIDE GUIDE
43	4	423288	SOC. HD. CAP SCREW M5 X 12
44	1	010114	GRIPPER PLUG
45	1	010115	PIVOT PIN
47	1	008852	HANDLE KNOB
48	1	023248	HANDLE WELDMENT
49	2	008154	FHSCS 5/16-18 X 1
50	1	422964	BASE HOUSING
51	1	020622	EJECTOR ARM PIN
52	2	005054	RETAINING RING, TRUARC #5100-31
53	1	423811	EJECTOR ARM SPRING
54	1	024415	EJECTOR
55	1	020629	EJECTOR SPRING

## PART LIST, Continued

<u>KEY</u>	<u>QTY.</u>	<u>PART NO.</u>	<u>DESCRIPTION</u>
56	1	020621	EJECTOR PIN
57	1	026866	RETAINING RING, TRUARC #5100-25
58	1	010106	EJECTOR LEVER
59	1	010112	STRAP GRIPPER
60	1	010108	GRIPPER LEVER
61	1	171807	LOW HEX NUT, M8
62	1	164956	SOCKET HEAD SHOULDER BOLT, M8 X 12 LG.
63	1	162403	SOCKET HEAD CAP SCREW M8 X 25 LG.
64	1	002395	GROOVED PIN, 5/16" DIA. X 7/8" LG., TYPE G
65	1	010109	GRIPPER SPRING
66	1	010165	CUTTER BLOCK
67	2	160331	SOCKET HEAD CAP SCREW, M8 X 20 LG.
68	1	160328	DOWEL PIN, 4MM DIA. X 20 LG.
69	1	422940	SEAL PAD ASSEMBLY
71	1	020640	MAGAZINE SPRING
72	2	004939	DRIVE SCREW, #2 X 3/16" LG.
73	1	010121	MAGAZINE
76	1	023231	SEALER HANDLE
77	1	023962	WARNING PLATE
77-1	1	180900	INFORMATION SIGN
78	1	010019	ROLL PIN, 1/4" DIA. X 1-1/8" LG.
80	1	023207	SEALER PINION
81	2	010158	SEALER PINION BEARING
82	1	422958	SEALER CAM
83	1	004727	FLAT WASHER
84	1	003868	LOCK NUT 3/8-24 THIN
85	1	010113	CUTTER BLADE
86	1	164619	ROLLER GUIDE
87	2	422961	JAW
88	2	013694	CAM ROLLER
89	2	005205	DOWEL PIN, .251 X .875
90	1	010150	JAW RETURN SPRING
91	2	160322	ROLL PIN, 3MM DIA. X 24 LG.
92	1	010157	RACK
93	1	010149	CAM
94	1	005461	ROLL PIN, 6MM DIA. X 34 LG.
95	1	164622	CHAIR
96	1	074391	RETAINING CLIP SPRING
97	1	024408	SEAL RETAINING CLIP
98	2	010152	JAW PIN
99	1	010155	JAW SUPPORT
100	1	003132	SAFETY SIGN
101	1	433394	NAMEPLATE
102	1	433399	SAFETY SIGN
	1	023963	BRUSH (NOT ILLUSTRATED)

- Applying light machine oil to all moving parts will increase the service life of this tool.
- When ordering parts please show tool model, part number and part name.
- Hardware sizes listed may be obtained at a local hardware supply.

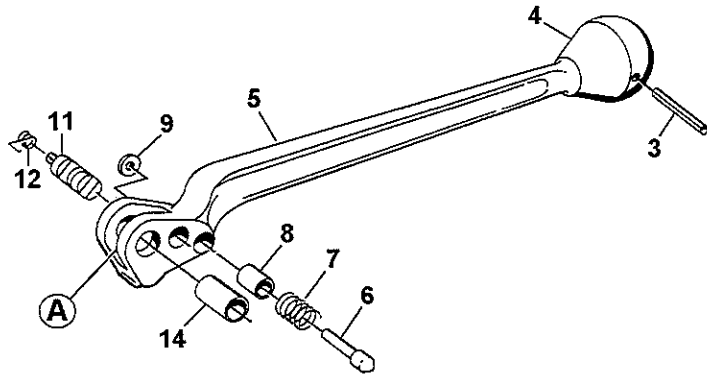

\* Use Loctite #242 (or equivalent).

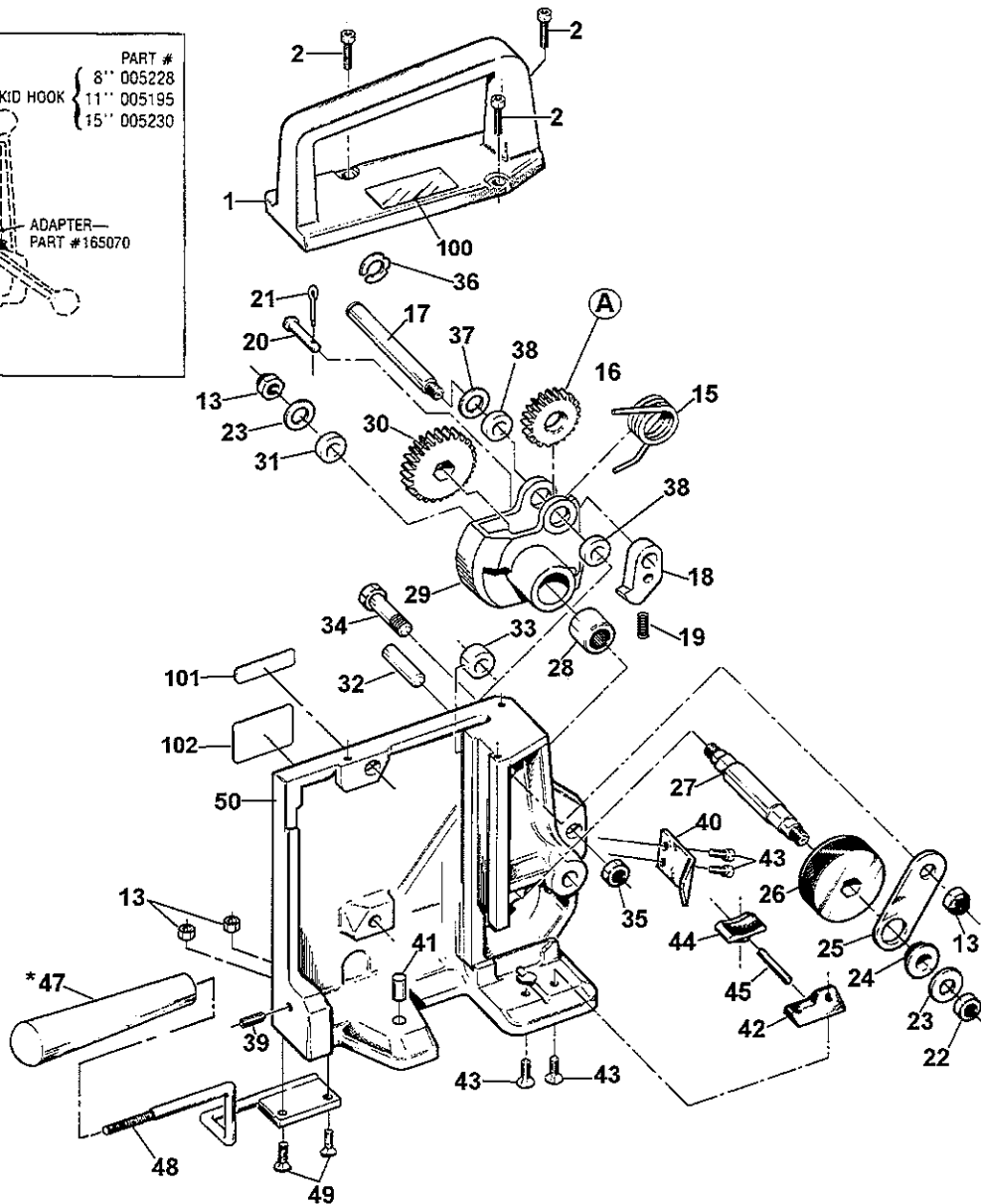
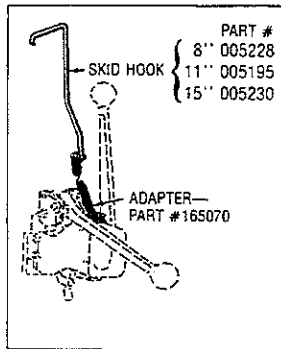

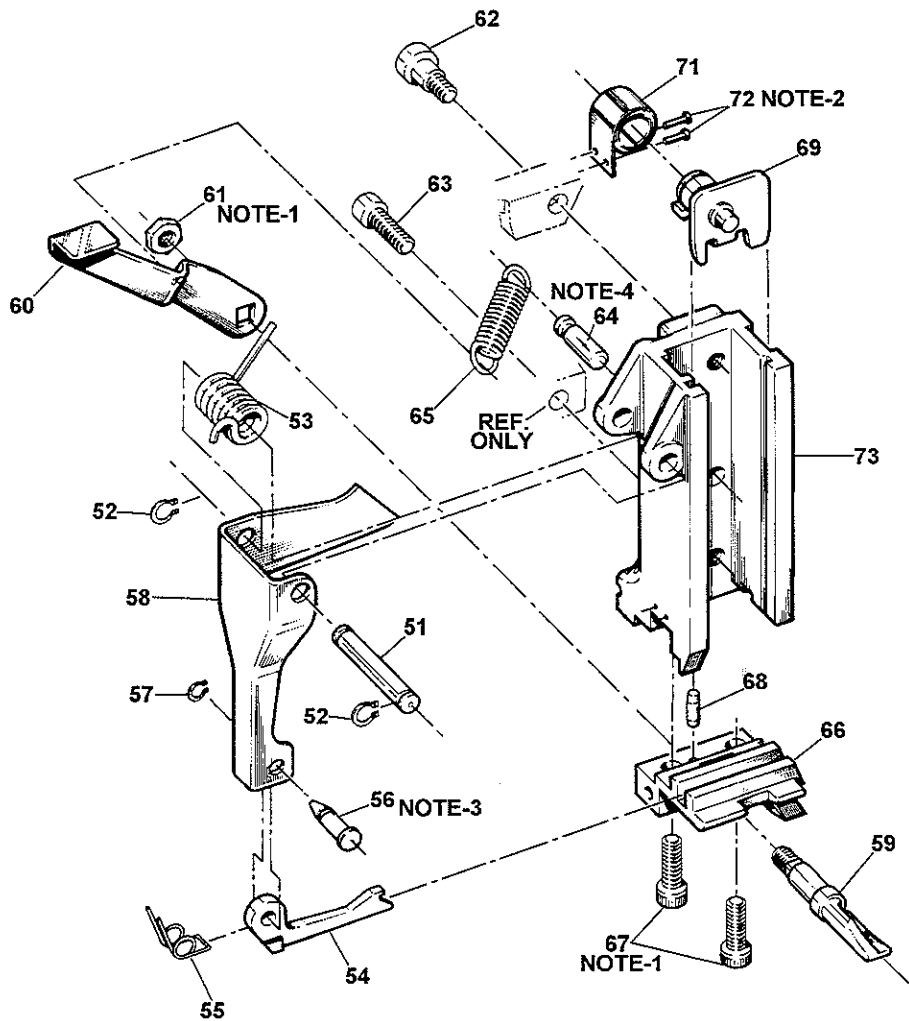

**⚠ WARNING**

All parts must be periodically inspected and replaced if worn or broken. Failure to do this can affect a product's operation and can result in personal injury.

**NOTES:**

1. Apply one drop of Loctite #242 (or equivalent) sealant to cleaned parts. Allow 12 hours to set if possible. Do not apply close to moving parts as liquid spreads easily.
2. Apply one drop of Loctite #271 (or equivalent) sealant to cleaned parts. Allow 12 hours to set if possible. Do not apply close to moving parts as liquid spreads easily.
3. Directional clip - assemble as shown.
4. Pin must be flush to 0.5mm below seal surface of magazine.

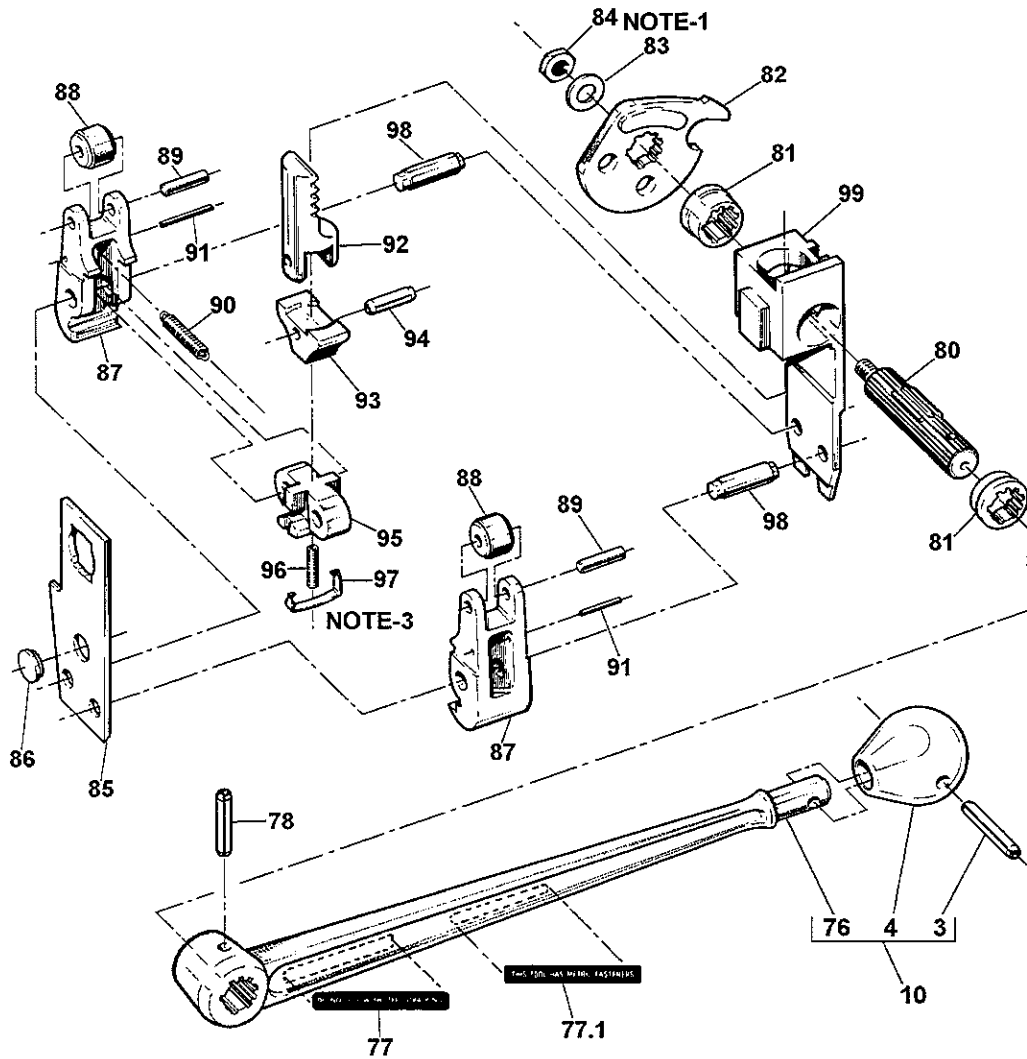

**⚠ WARNING**

All parts must be periodically inspected and replaced if worn or broken. Failure to do this can affect a product's operation and can result in personal injury.





**SIGNODE  
NEW TOOL WARRANTY**

Signode Engineered Products Warrants that a new Signode strapping tool will operate per functional specifications for a period of sixty (60) days after the date of shipment to the owner's place of business. Normal wearing parts, as outlined in the Operation, Parts & Safety manual, are covered by a thirty (30) day warranty unless, in Signode's judgement, these parts have been subjected to abnormal or extreme usage. Signode's sole liability hereunder will be to repair or replace, without charge, F.O.B. Signode's Glenview, Illinois plant, any tool which proves to not operate per functional specifications within the stated period. Signode reserves the right to replace any tool which proves not to operate per functional specifications with a new or like-new tool of the same model if in Signode's judgement such replacement is appropriate. Any new replacement tool provided to an owner will carry a full sixty (60) day warranty. Any warranty repaired tool or like-new replacement tool will carry a warranty for the balance of the time remaining on the initial sixty (60) day warranty. This warranty will be extended to compensate for the time the tool is in Signode's possession for warranty repairs.

This warranty is void as to any tool which has been: (I) subjected to mis-use, misapplication, accident, damage, or repaired with other than genuine Signode replacement parts, (II) improperly maintained, or adjusted, or damaged in transit or handling; (III) used with improperly filtered, unlubricated air or improper strapping material, (IV) in Signode's opinion, altered or repaired in a way that affects or detracts from the performance of the tool.

SIGNODE MAKES NO WARRANTY, EXPRESSED OR IMPLIED, RELATING TO MERCHANTABILITY, FITNESS OR OTHERWISE EXCEPT AS STATED ABOVE AND SIGNODE'S LIABILITY AS ASSUMED ABOVE IS IN LIEU OF ALL OTHERS ARISING OUT OF OR IN CONNECTION WITH THE USE AND PERFORMANCE OF THE TOOL. IT IS EXPRESSLY UNDERSTOOD THAT SIGNODE SHALL IN NO EVENT BE LIABLE FOR ANY INDIRECT OR CONSEQUENTIAL DAMAGES INCLUDING, BUT NOT LIMITED TO, DAMAGES WHICH MAY ARISE FROM LOSS OF ANTICIPATED PROFITS OR PRODUCTION, SPOILAGE OF MATERIALS, INCREASED COSTS OF OPERATION OR OTHERWISE.

Considerable effort has been made to ensure that this product conforms to our high quality standards. However, should you experience any difficulties, please contact your Sales Representative providing samples and the manufacturing code specified on the tool.

Thank you for your help.

**SIGNODE ENGINEERED PRODUCTS**  
Hand Tool Division  
3620 W. Lake Avenue, Glenview, Illinois 60025

PART #	DESCRIPTION	AREA OF USE
<b>LUBRICANTS</b>		
177029	BROWN K-55 GREASE	CLUTCH DRIVES, INTERNAL GEARS, GEAR SETS
422792	WHITE LUBRIPLATE GR-132 GREASE	PNEUMATIC PARTS, AIR CYLINDERS, AIR VALVES, O-RINGS
422793	BLACK LUBRIPLATE 3000W GREASE	MOVING INTERNAL PARTS, JAWS, LINKS
432322	EP ACCROLUBE GREASE	HIGH FRICTION CONTACT PARTS
008556	LS-1236 AIR LINE OIL	AIR MOTORS, AIR VALVES
<b>ADHESIVES</b>		
422794	LOCTITE #222, PURPLE	LOW STRENGTH, SCREWS 1/4" (6MM) OR SMALLER SIZES
422795	LOCTITE #242, BLUE	MEDIUM STRENGTH, SCREWS 5/16" (8MM) OR LARGER SIZES
422796	LOCTITE #271, RED	HIGH STRENGTH, SEMI-PERMANENT SCREW APPLICATION
422797	LOCTITE #609, GREEN	PERMANENT, CURVED SURFACE PART CONTACT
274111	LOCTITE #380, BLACK MAX	PERMANENT, FLAT SURFACE PART CONTACT
<b>CLEANING BRUSHES</b>		
023963	SMALL BRUSH	FEEDWHEEL & GRIPPER TEETH
269589	LARGE BRUSH	FEEDWHEEL & GRIPPER TEETH