

# OPERATION, PARTS AND SAFETY MANUAL



# **SIGNODE®**

**PRHR-34/114  
PUSH TYPE POWER COMBINATION  
STRAPPING TOOL**

**IMPORTANT!  
DO NOT DESTROY**

**It is the customer's responsibility to  
have all operators and servicemen  
read and understand this manual.**

Contact your local Signode representative  
for additional copies of this manual.

***READ ALL INSTRUCTIONS BEFORE OPERATING THIS SIGNODE PRODUCT***

---

**SIGNODE • 3620 WEST LAKE AVENUE • GLENVIEW, ILLINOIS 60025 U.S.A.**

---

# **WARNING**

READ THESE INSTRUCTIONS CAREFULLY.

FAILURE TO FOLLOW THESE INSTRUCTIONS CAN RESULT IN SERIOUS PERSONAL INJURY.

## GENERAL SAFETY CONSIDERATIONS

### 1. STRAP BREAKAGE HAZARD.

Improper operation of the tool or sharp corners on the load can result in strap breakage during tensioning, which could result in the following:

- ! A sudden loss of balance causing you to fall.
- ! Both tool and strap flying violently towards your face.

Failure to place the strap properly around the load or an unstable or shifted load could result in a sudden loss of strap tension during tensioning. This could result in a sudden loss of balance causing you to fall.

- ! If the load corners are sharp use edge protectors.
- ! Positioning yourself in-line with the strap, during tensioning and sealing, can result in severe personal injury from flying strap or tool. When tensioning or sealing, position yourself to one side of the strap and keep all bystanders away.

### 2. TRAINING.

This tool must not be used by persons not properly trained in its use. Be certain that you receive proper training from your employer. If you have any questions contact your Signode Representative.

### 3. EYE INJURY HAZARD.

Failure to wear safety glasses with side shields can result in severe eye injury or blindness. Always wear safety glasses with side shields which conform to ANSI Standard Z87.1 or EN 166.



### 4. FALL HAZARD.

Maintaining improper footing and/or balance when operating the tool can cause you to fall. Do not use the tool when you are in an awkward position.

### 5. CUT HAZARD.

Handling strap or sharp parts could result in cut hands or fingers. Wear protective gloves.



### 6. TOOL CARE.

- ! Inspect and clean the tool daily. Replace all worn or broken parts.
- ! Lubricate all moving parts daily.
- ! On air powered tools, always disconnect the pneumatic connection to the tool when performing part removal and replacement procedures. NEVER connect a pneumatic source to a disassembled tool unless otherwise specified.

### 7. WORK AREA.

Keep work areas uncluttered and well lighted.

# **! WARNING**

Use the correct Signode products for your application. If you need help contact your Signode Representative.

Signode tools and machines are designed and warranted to work together with Signode strapping and seals. Use of non-Signode strap, seals and/or manufactured or specified replacement parts may result in strap breakage or joint separation while applying strapping to a load or during normal shipping and handling. This could result in severe personal injury.

## **JOINT FORMATION**

An improperly formed joint, or a joint with an incorrect number of notches, could result in strap separation. Before moving any package, be certain that the joint is formed as shown in the illustration. If not, remove the strap and check the tool for worn or broken parts. Repair the tool before applying another strap. Failure to follow this procedure could result in serious injury or death. If you have questions regarding proper joint formation, contact your Signode Sales Representative.

Before making a double reverse notch seal joint, read the sealing tool's Operation. Parts and Safety Manual. A properly formed double reverse notch joint will appear as shown in the illustration. More than one seal may be required for your application. Always use the correct number of seals recommended by your Signode Sales Representative.



If the double reverse notch joint does not appear as shown in the illustration proceed as follows:

1. Review the tool's operating instructions to be certain that the tool is being operated properly before applying another strap.
2. Cut the strap off, and apply a new strap and seal.

## **MOVING AND STACKING STRAPPED LOADS**

Before moving or stacking any strapped load, follow all standard industry practices regarding safe material handling procedures.

## **CUTTING TENSIONED STRAP**

Using claw hammers, crowbars, chisels, axes or similar tools will cause tensioned strap to fly apart with hazardous force. Use only cutters designed for cutting strap. Read the instructions in the cutters manual for proper procedure in cutting strap. Before using any Signode product read its Operation and Safety Manual.

## **TOOL CLEANING & LUBRICATION**

Clean and apply a light weight machine oil to all moving parts on a weekly basis. Clean the feedwheel daily with a wire brush. Refer to the Pneumatic Information shown in this manual for lubricant recommendations with regard to the air motor.

## TABLE OF CONTENTS

	Page
General Safety Instructions	2
Specifications	4
Tool Installation	4
Major Components	5
Pneumatic Information	6
Strap Tension	8
Operating Instructions	9
Tool Adjustments	11
Troubleshooting	12
Parts List & Exploded Views	14
Declaration of Conformity	27

## **⚠ WARNING**

Signode tools and machines are designed and warranted to work together with Signode strapping and seals. Use of non-Signode strap, seals and/or manufactured or specified replacement parts may result in strap breakage or joint separation while applying strapping to a load or during normal shipping and handling. This could result in serious personal injury.

PRHR-34  
Part No. 424234

PRHR-114  
Part No. 423570

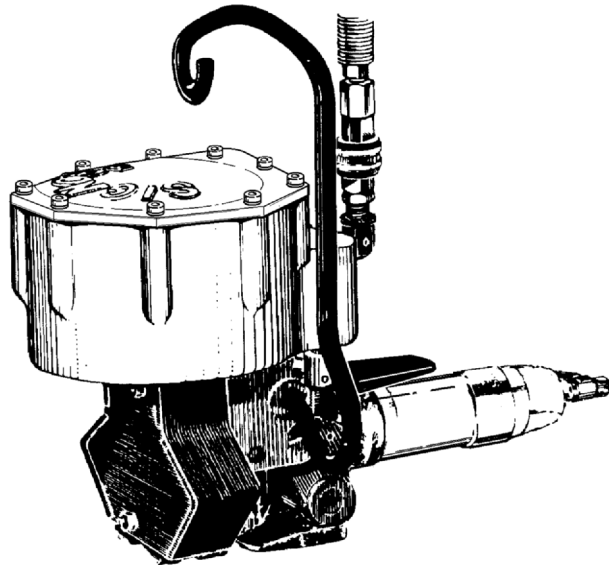

## SPECIFICATIONS

MODEL	STRAP			SEALS
	TYPE	WIDTH	THICKNESS	
PRHR-34	MAGNUS PAINT & WAX	3/4"	0.025" Minimum 0.031" Maximum	34P
PRHR-114*		1-1/4"		114P

\* Refer to page 18 of this manual for information on 0.044" strap conversion.

## TOOL INSTALLATION

To work effectively, the PRHR Tool must be properly installed. This installation includes, in some cases, proper suspension of the tool over the container to be strapped and the proper placement of the strapping dispenser to provide a continuous easy supply of strapping for the application.

## MAJOR COMPONENTS

To better operate the PRHR become familiar with the major components of the tool.

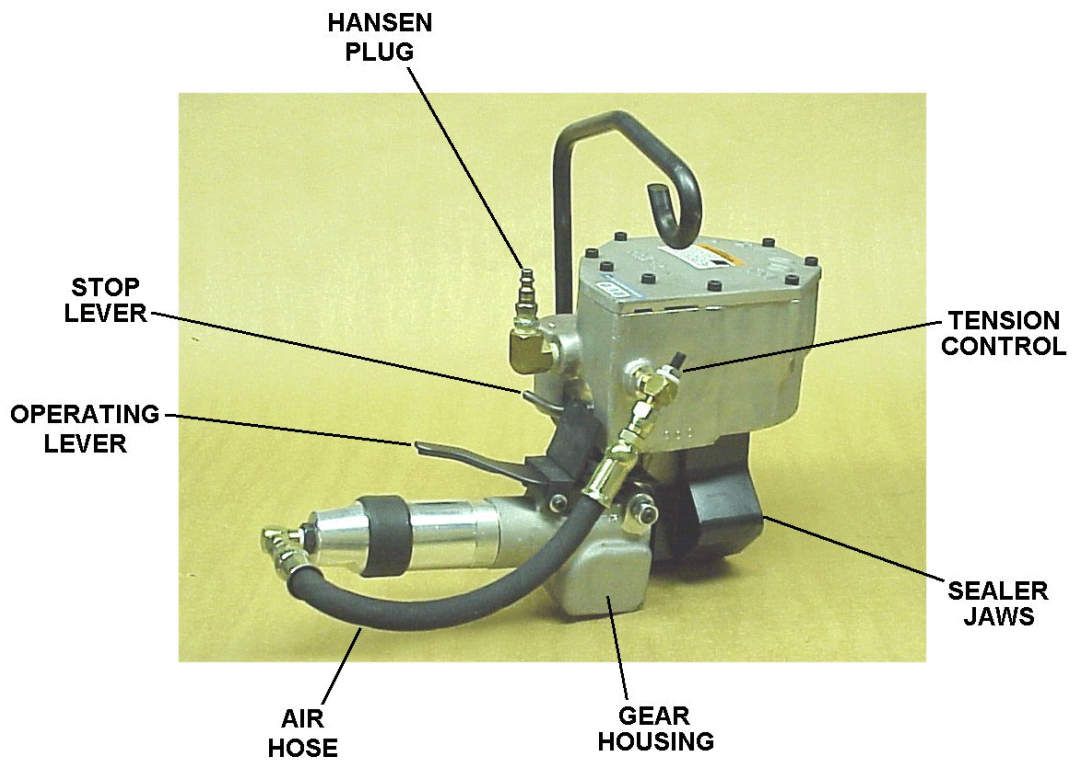
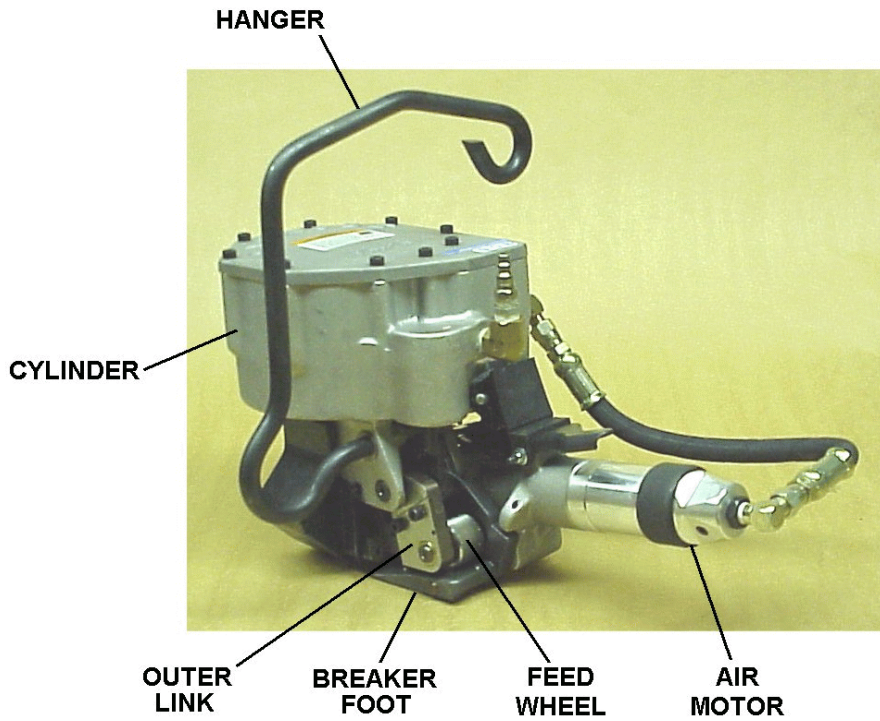

## PNEUMATIC INFORMATION

### Air Supply Installation

If the compressor has a good dryer unit, use black pickled pipe. When a dryer unit is not installed, use galvanized or copper pipe.

To perform reliably, a pneumatic tool requires a continuous source of clean, water-free air at adequate pressure.

# ⚠ WARNING

Never operate this tool using a bottled air or gas source. Bottled air/gas sources do not provide consistent operating pressure and could result in air pressures that exceed the maximum allowed for the tool.

A filter-regulated-lubricator unit (Signode Part No. 008559) must be installed as close to the air tool as possible, preferably within 10 feet. It should be placed in a convenient location where it can easily be drained, adjusted, and filled with oil. The air hose must have at least a 3/8" I.D.. A quick-connect press-on socket is installed on the stress spring end of the hose for convenient hookup to the air tool.

Filter and lubricator bowls are made of polycarbonate material. Do not install where bowls may be exposed to materials incompatible with poly carbonate. Certain oils, solvents, and chemicals or their fumes can weaken these bowls and possibly cause them to burst. Clean only with warm water. A cut-off valve placed ahead of the filter will be useful when cleaning the filter or replenishing the lubricator.

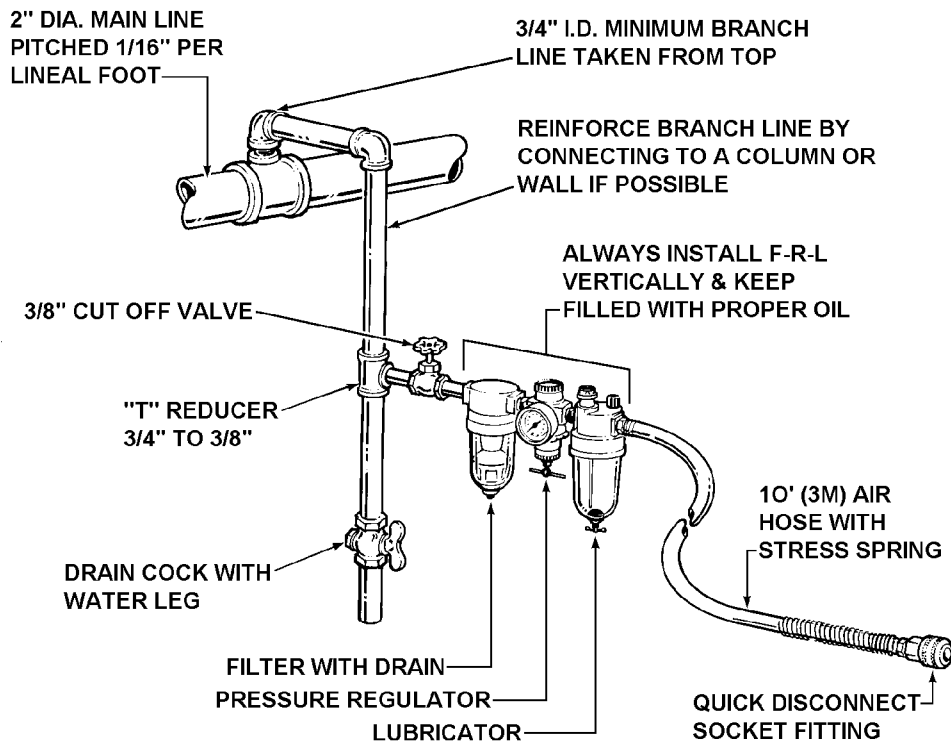

## MOISTURE

Moisture is always present in air lines due to condensation within the lines as the air cools. Steps must be taken to remove this moisture and to keep it from the air tool. This is because water tends to wash away lubricants and cause corrosion, sticking and failure of internal parts.

The main line should be pitched so the far end terminates in a water leg. Branch lines are taken from the top of the main, never off the bottom. Every branch should have a water leg at its lowest point, with a drain cock which is drained daily.

If these precautions are taken and water is still present, an after cooler and a moisture separator are required between the compressor and the air receiver tank. A large air line separator can be installed in the air tool line, but precautions must be taken to insure that it will be drained daily, before the air tool is operated.

Water in air lines is a constant threat to the proper operation of air tools. Even near freezing operating conditions, a good refrigerant type dryer is essential. A good dryer will remove 95% or more of water right at the compressor. The remaining moisture is removed at the water leg in the piping system or in the filter (Part No. 173111).

**NOTE:** Additional information is available in the Signode publication, "Air Supply Manual" (Part No. 186038). If you have any questions, contact your local Signode Representative.

## LUBRICATION

The air motor must be properly lubricated. This is achieved by keeping the air line lubricator filled with oil and correctly adjusted. Without proper lubrication, the motor will become sticky and the tool will give low and erratic tension and be difficult to release from the strap.

Install the lubricator as close to the air tool as possible. The arrow on the lubricator's top surface must point in the direction of air flow. For proper operation, oil must drop through the lubricator sight glass at a rate of 1 to 4 drops per minute. This rate is checked while the air tool is running free. Only 20% of this oil is actually delivered to the tool. The remaining oil drops back into the oil reservoir. The unit is factory set and should require no adjustment. If an adjustment is required, the adjusting screw on top of the lubricator may be turned as marked to reduce or increase the flow of oil.

The correct grade of oil must be used in the lubricator; too heavy an oil will not provide sufficient lubrication and will cause sticking and sluggish operation of the air tool. Recommended oils are any good grade of rust and oxidation inhibiting oil with a viscosity of 80-120 S.U.S. at 100 degrees Fahrenheit. (0.15 to 0.25 cm<sup>2</sup> /sec. at 38 degrees Celsius), such as:

Non Fluid Oil Co., grade #LS-1236

Signode oil - Part No. 008556

If necessary, use SAE #5 or SAE #10 non-detergent, cut 1 to 1 with kerosene.

**NOTE:** Some oils contain anti-wear additives which may disable the air motor. Be certain to use recommended oil.

Several drops of lubricator oil added to the inlet of the air motor or into the air line each day will help insure good operation. A noticeable reduction of air motor performance can usually be corrected by squirting a few drops of oil into the air line.

## PNEUMATIC INFORMATION, Continued

### COLD WEATHER OPERATION

If a tool does not operate satisfactorily in freezing temperatures, certain steps can correct the problem. The following steps can be taken to improve cold weather operation of the tool:

- a. An air line dryer adjacent to the compressor.
- b. Use lubricant recommended by Signode. Signode has tested the use of anti-freezes, none work well in air tools; the tool will gum up when anti-freezes are introduced and will not function properly. The best lubricant for freezing weather is the 1 to 1 oil and kerosene combination.
- c. If possible, run the air supply line to a indoor located Filter-Regulator-Lubricator or relocate the F-L-R to a warmer operating area.

### AIR PRESSURE vs. STRAP TENSION

A minimum air pressure setting of 70 psig must be maintained to ensure that the tool will seal properly. Input air pressure to tool must not exceed 90 psig. Strap tension is controlled by air pressure. Use the proper air line piping and lubrication as specified in this manual. Your air pressure gauge must be accurate, therefore, confirm its accuracy by comparing it to a calibrated master gauge.

Adjust the pressure regulator to achieve the tensions listed below. Once the regulator is set, the tension levels will be consistent on all straps, provided the operator allows the air motor to stall. If the air pressures do not result in tension levels that satisfy the needs of the application, then increase the air pressure in increments of 5 psig until the desired tension level has been achieved.

### STRAP TENSION

## **WARNING**

Strap breakage hazard. Increasing the tension can result in strap breakage. 1-1/4" Strap can break during tensioning if inlet air pressure exceeds 90 psig (6.1 BAR). Maximum operating air pressure is 90 psig (6.1 BAR). Never remove the adjusting screw from the tool with the air connected. The screw could become a flying projectile. Failure to follow the above could result in serious personal injury.

Strap tension is accurately controlled by air pressure to the tool and the setting of the adjusting screw. Once the desired inlet air pressure and the adjusting screw settings have been established, tension will be uniformed on all straps.

The PRHR tool has been factory adjusted to draw 1400 lbs. (6216 N) of tension at 90 psig (6.1 BAR). A minimum of 70 psig (4.8 BAR) is required to ensure that the tool will seal properly.

To adjust the tension:

1. Make sure the air pressure is set between 70 and 90 psig (4.7 an 6.1 BAR).
2. Loosen the hex nut (81) and turn the adjusting screw (80) clockwise to decrease tension and counterclockwise to increase tension.
3. Retighten the hex nut.



## OPERATING INSTRUCTIONS

### **⚠ WARNING**

Wear safety glasses which conform to ANSI Standard Z87.1 or EN 166.

Stand to one side of the strap while tensioning.  
Make sure all bystanders are clear before proceeding.

Failure to follow the above could result in serious personal injury.

#### STRAP AND SEAL LOADING

Refer to the Specifications section to make sure the seal has been chosen. Insert the lead end of the strap into the seal Signode No. 114P.

Pass the strap over the top of the package then bring the lead end around and up and rethread it into the seal. This will result in creating a TOP STRAP and a BOTTOM STRAP. They will be referred to later in these instructions.

Bend about 2 1/2" (63.5mm) of the lead end of the BOTTOM STRAP back beneath the seal to maintain the loop. Refer to Figure 1 to make sure the loop has been properly formed. Hold the BOTTOM STRAP and pull back on the TOP STRAP to draw loop loosely around the package. A gentle upward bend on the TOP STRAP will hold the loop in place while the PRH2 tool is being positioned.

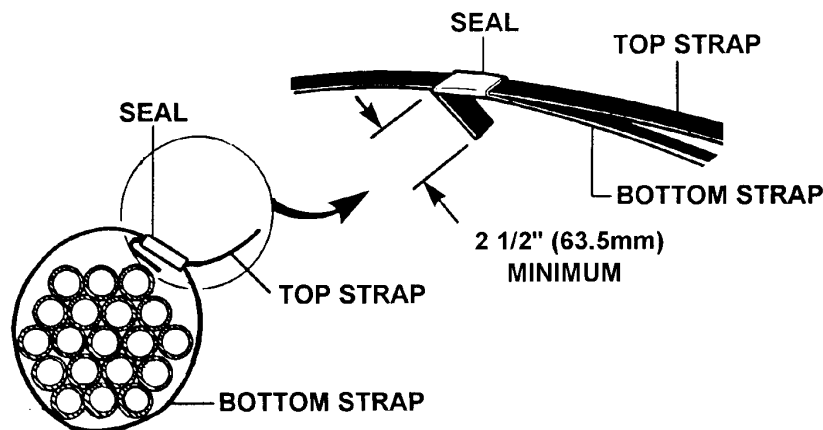

## OPERATING INSTRUCTIONS, Continued

### CYCLING THE TOOL

1. Grasp the **TOP STRAP** and insert it sideways into the tool between the feedwheel and the breaker foot. Make sure the strap is in full contact with the inside surface of the breaker foot. When the **TOP STRAP** is properly loaded, the sealing mechanism will be in line with the seal.

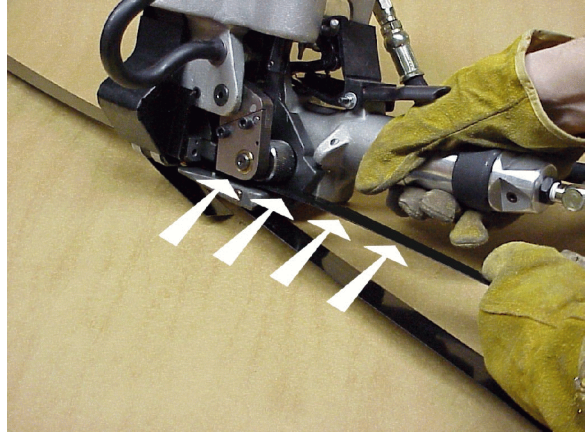

2. Push the tool forward until the seal-stop contacts the end of the seal.

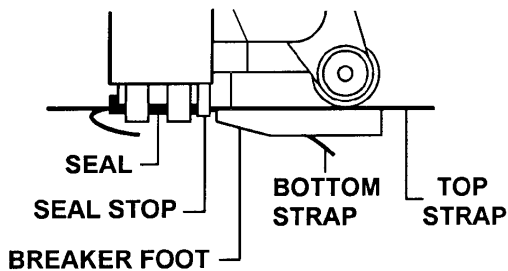

Pull back on the **TOP STRAP** to eliminate additional slack around the package. You will have to push on the cylinder cover to make certain that the jaw tips are in position over the seal.

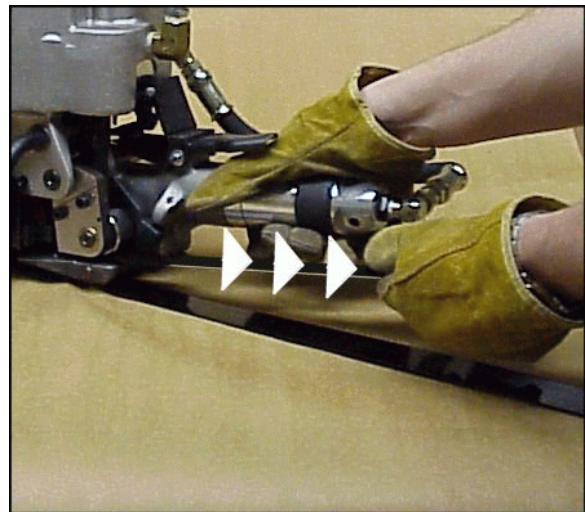

*Note: Before continuing, make sure the **TOP STRAP** and the seal is still in position, as described above. Note that the **BOTTOM STRAP** will be positioned in the channel on the bottom surface of the breaker foot. This too, is necessary to maintain strap alignment during tensioning.*

3. While standing to one side of the strap, press the operating lever all the way down and then release it.

The air motor will turn the feedwheel and the feedwheel will tension the strap around the package until the present tension level has been reached, at which time the air motor will stall.

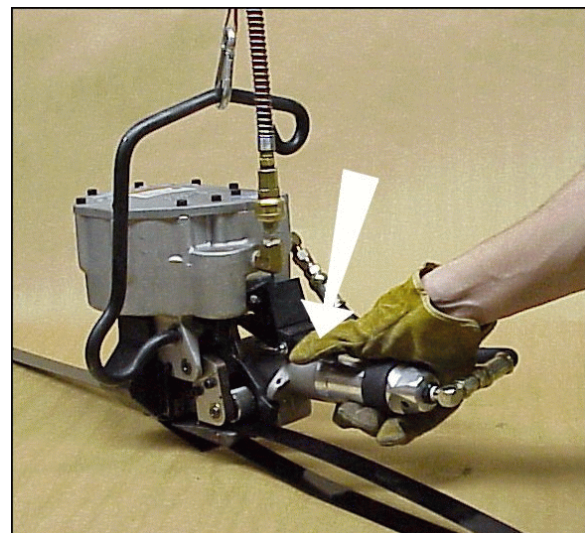

4. If strap alignment is unsatisfactory and it becomes necessary to shut off the tool during the tensioning portion of the cycle, push down on the stop lever.

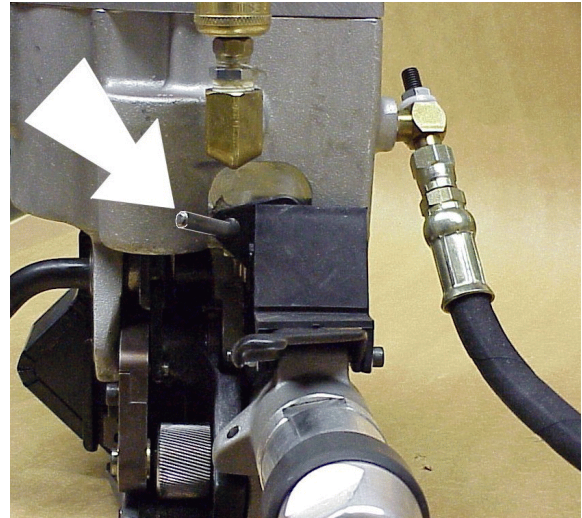

5. Press down on the operating lever once again. Air will be routed to the sealing mechanism to notch the seal/strap, cut-off the TOP STRAP and raise the feedwheel to allow the tool to be removed from the completed tie.

Lift the PRHR tool from the tie and closely inspect the joint to make sure the tool has properly notched the seal.

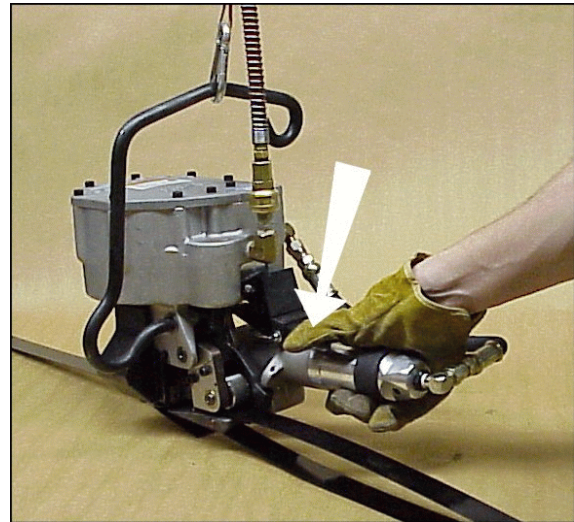

## JOINT FORMATION

An improperly formed joint, or a joint with an incorrect number of notches, could result in strap separation. Before moving any package, be certain that the joint is formed as shown in the illustration. If not, remove the strap and check the tool for worn or broken parts. Repair the tool before applying another strap. Failure to follow this procedure could result in serious injury or death. If you have questions regarding proper joint formation, contact your Signode Sales Representative.

Before making a double reverse notch seal joint, read the sealing tool's Operation, Parts and Safety Manual. A properly formed double reverse notch joint will appear as shown in the illustration. More than one seal may be required for your application. Always use the correct number of seals recommended by your Signode Sales Representative.

If the double reverse notch joint does not appear as shown in the illustration proceed as follows:

1. Review the tool's operating instructions to be certain that the tool is being operated properly before applying another strap.
2. Cut the strap off, and apply a new strap and seal.

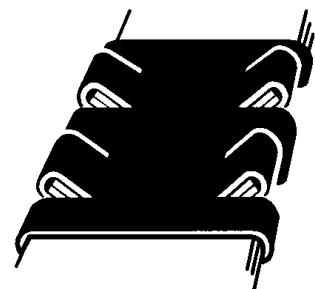

## TROUBLESHOOTING

The following items are the most common tool symptoms if problems should occur. For symptoms or remedies not shown, contact your Signode service representative for additional information and details. The following tool symptoms are shown in this manual:

- #1 SYMPTOM: Inadequate strap tension.
- #2 SYMPTOM: Feedwheel milling or slipping.
- #3 SYMPTOM: Incomplete sealing & cut off.
- #4 SYMPTOM: Strap slipping through seal.
- #5 SYMPTOM: Low joint strength.
- #6 SYMPTOM: Seal slipping into tool nose.

<b>#1 SYMPTOM: Inadequate strap tension.</b>	
<b>CAUSE</b>	<b>REMEDY</b>
1. Improper strapping being used.	1. Check that Signode lubricated strap is used.
2. Supply air pressure is set incorrectly.	2. Make sure that the air pressure is set between 70-90 psig (4.8-6.1 BAR) at the tool.
3. Air regulator at tool is set incorrectly.	3. Adjust tension regulator.
4. Filter screen clogged.	4. Check for particles restricting air flow in the regulator or screen at end of motor.
5. Improper amount of oil in the supply air.	5. Check lubricator operation and pour one tablespoon of lubricating oil into tool inlet.
6. Worn or broken air hose.	6. Check for restrictions or deterioration of supply hose.
7. Back up roller (44) restricting strap movement through tool.	7. Check that the backup roller (44) is free to rotate.

<b>#2 SYMPTOM: Feedwheel milling or slipping.</b>	
<b>CAUSE</b>	<b>REMEDY</b>
1. Dirty or clogged feedwheel.	1. Clean feedwheel teeth.
2. Worn or broken feedwheel.	2. Check feedwheel (49). Replace if teeth are broken or blunt. Inspect for proper rotation orientation.
3. Improper feedwheel clearance.	3. Check feedwheel clearance.
4. Worn feedwheel shaft bearings.	4. Check feedwheel shaft outer bearing (50) for extreme elongation. Replace if necessary.
5. Restricted movement of energizing piston.	5. Check feedwheel energizing piston for freedom of movement. make sure the air has been disconnected from the tool before proceeding.

**#3 SYMPTOM: Sealing and cutoff incomplete.**

CAUSE	REMEDY
1. Improper supply air pressure.	1. A minimum of 70 psig (4.8 BAR) at the tool is required to complete the sealing cut off cycle. The sealer mechanism may be returned to the starting position by releasing the stop lever as explained in the Operating Instructions.
2. Incorrect seals being used for tool.	2. Check that Signode 114P seals are being used.
3. Worn or broken sealer jaws	3. Check jaws (94), side plates (85,96), notcher (88), and cutter (36) or leading edge breaker foot (43). They should be reasonably sharp. Replace as required.

**#4 SYMPTOM: Lower strap slipping through seal.**

CAUSE	REMEDY
1. Incorrect seals being used for tool.	1. Check that Signode 114P seals are being used.
2. Improper supply air pressure.	2. Decrease tension by adjusting regulator of air motor.
3. Strap tail is too short when threading seal.	3. Increase length of tail strap under seal.

**#5 SYMPTOM: Low joint strength.**

CAUSE	REMEDY
1. Incorrect seals being used for tool.	1. Check that Signode 114P seals are being used.
2. Worn or broken sealer jaws. Inspect strap joint for proper formation.	2. Replace worn or broken jaws, notchers, side plates or pins.

**#6 SYMPTOM: Seal slipping into nose of tool.**

CAUSE	REMEDY
• Incorrect seals being used for tool.	1. Check that Signode 114P seals are being used.
• Incorrect tool tolerances.	2. Check nose opening between breaker foot (43) and cutter housing (39). Opening should be .034" to .044". If opening exceeds this, check respective parts and replace if necessary.

## PARTS LIST

<u>KEY</u>	<u>QTY</u>	<u>PART NO.</u>	<u>DESCRIPTION</u>
1	9	174149	SHCS, M6 x 25
4	1	423416	Cylinder cover
5	1	004152	Cylinder gasket
6	1	004104	Conical compression spring
7	1	004166	O ring, 5 3/4 x 6 1/8 x 3/16"
8	1	423573	Nylock nut, M10 x 1.25
10	1	423410	Sealer piston
11	1	423568	SHSS, M8 x 30
12	1	423405	Cylinder
13	1	005460	Roll pin, 6 x 20
14	1	423395	Elbow, regular
16	1	<u>004131</u>	<u>Valve latch spring</u>
17	1	<u>423555</u>	<u>Valve latch</u>
18	1	023670	Shoulder screw
19	1	004111	Upper sleeve spacer
20	1	004193	Upper sleeve spacer
21	2	423563	Valve spring (LC055H-12)
22	7	004165	O ring, 3/4 x 1 x 1/8"
23	5	423414	Valve sleeve
24	1	004113	Lower sleeve spacer
25	1	004114	Tensioner valve stem
26	1	004115	Sealer valve stem
27	1	004144	Lower valve spacer
28	1	023677	Hansen socket
29	1	020704	Hansen socket
30	1	008478	Bushing
31	1	004190	Street elbow
32	1	422130	Hanger
33	1	071581	Washer
34	1	004637	Locknut, 1/2-12
48	1	423572	Roll pin, 8 x 24
64	1	423412	Pivot shaft
65	1	020701	O ring, 7/32 x 11/32 x 1/16"
66	1	423393	<u>Stop lever</u>
67	1	004130	<u>Spring</u>
68	1	004136	Cover plate
69	1	306047	SHSS, M5 x 6
70	2	423288	SHCS, M5 x 12
71	1	422837	Nylock nut, M8
73	1	280840	Roll pin, 3 x 16
74	1	004109	Valve handle spring
75	1	423413	Roll pin, 3 x 10
76	1	004138	Valve arm
77	2	004106	Valve arm roller
102	1	171655	Nylon washer
103	1	433398	Warning sign
110	1	006594	O ring, 5/8 x 13/16 x 3/32"
111	1	286373	Information sign.
112	1	424230	Nameplate (PRHR-34)
	1	436121	Nameplate (PRHR-114)
113	1	424237	Washer, 13mm ID x 24mm OD x 2.5mm thick
114	2	423584	Belleville spring washer, B-1000-073

### **⚠ WARNING**

Inspect all parts daily and replace them if they are worn or broken. Failure to do this can affect a product's operation and could result in serious personal injury.

The conical compression spring (6) is compressed and is under tension. Use car when removing the cylinder cover (4).

Failure to follow the above could result in serious personal injury.

- ! When ordering parts, please show tool model, part number and description.
- ! Wearing parts are usually limited to those underlined and should be stocked.
- ! Standard hardware may be obtained at any local hardware supply.

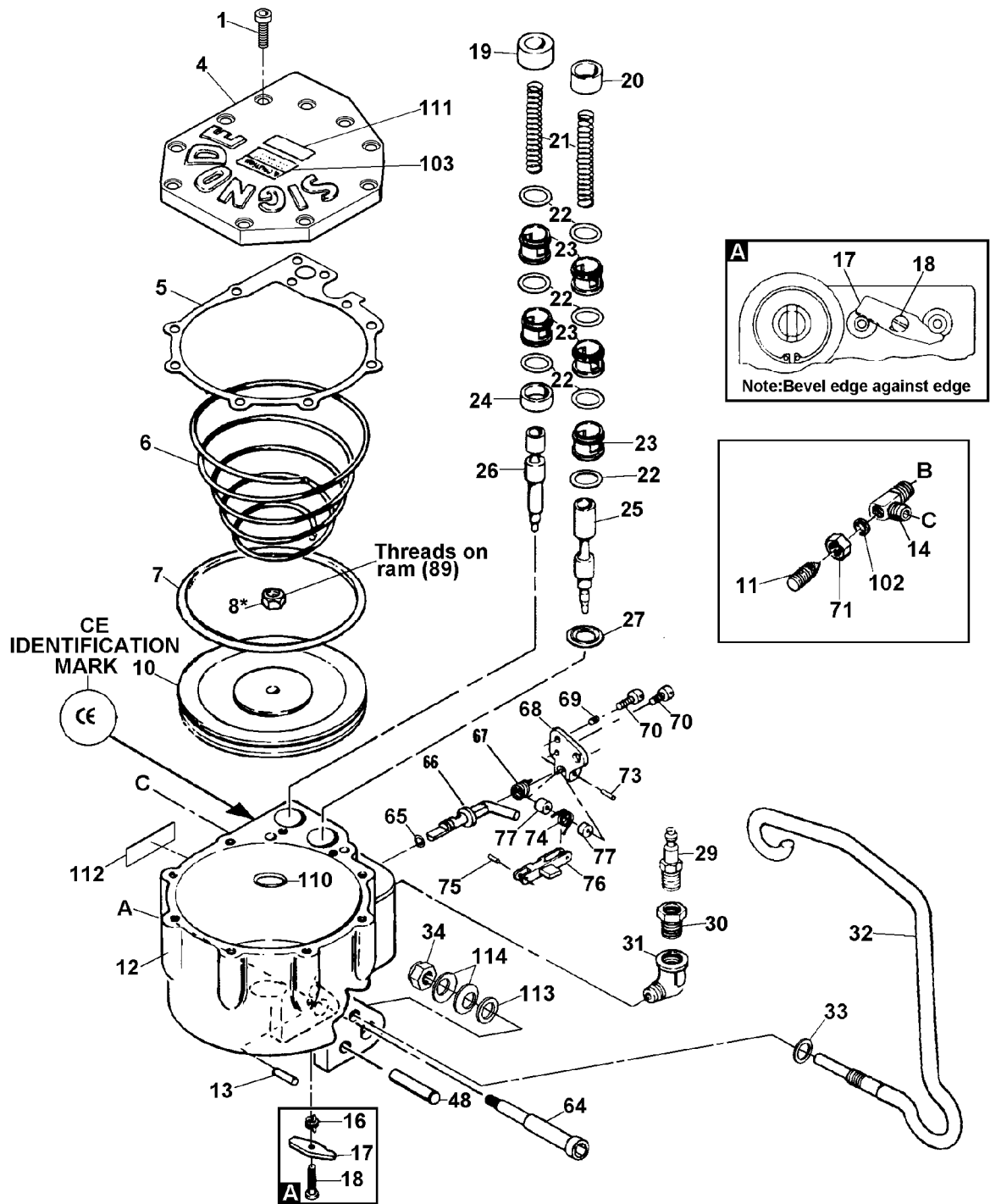

\* Apply one drop of Loctite #242 or equivalent to cleaned parts. Allow 12 hours to set, if possible. Do not apply to small screws or close moving parts as the fluid spreads easily.

NOTE: Torque socket head cap screws (Key 1) to 100-120 in-lbs (11.3-13.6 Nm).

## PARTS LIST , Continued

<u>KEY</u>	<u>QTY</u>	<u>PART NO.</u>	<u>DESCRIPTION</u>
1	2	174149	SHCS, M6 x 25
8	1	423573	Nylock nut, M10 x 1.25
15	1	423355	Air hose assembly
35	1	280819	Locknut, M5
36	1	<u>306509</u>	<u>Cutter</u>
37	1	<u>015626</u>	<u>Cutter spring, Lee #LC-029C-10</u>
39	1	423397	Cutter housing
40	1	162374	SHCS, M6 x 30
41	2	280840	Roll pin, 3 x 16
42	1	<u>424442</u>	<u>Seal stop (34)</u>
	1	<u>423559</u>	<u>Seal stop (114)</u>
43	1	<u>423401</u>	<u>Breaker foot</u>
44	1	423517	Backup roller
45	1	423553	Roller pin
46	1	250310	Roll pin, 4 x 16
47	1	423572	Roll pin, 8 x 24
49	1	<u>423398</u>	<u>Feedwheel</u>
50	1	<u>008863</u>	<u>Outer bearing</u>
52	2	253596	Dowel pin, 6 x 14
53	1	013538	O ring, 1 3/8 x 1 9/16 x 3/32"
54	1	423408	Position piston
55	1	004163	O ring, 1 3/8 x 1 1/2 x 1/16"
56	1	423409	Cylinder plug
57	1	004167	Retaining ring
58	1	006594	O ring, 5/8 x 13/16 x 3/32
60	1	423554	Roll pin, 5 x 16
61	1	423562	Piston link
62	1	423406	Outer link, upper
63	1	423571	Dowel pin, 6 x 20
78	1	423556	SHCS, M5 x 55
79	1	423565	Lever assembly
80	1	423407	Outer link, lower
81	4	010032	SHCS, M6 x 12
82	1	020710	Regulator elbow
100	1	010078	Split lock washer, M10
106	1	173955	Guard
107	1	006057	Washer, #10 SAE
108	1	423560	PRHR tension unit
109	1	424229	Dowel pin (PRHR-34)
110	1	423392	Shim (PRHR-1444 conversion kit)

- ! When ordering parts, please show tool model, part number and description.
- ! Wearing parts are usually limited to those underlined and should be stocked.
- ! Standard hardware may be obtained at any local hardware supply.

### **WARNING**

Inspect all parts daily and replace them if they are worn or broken. Failure to do this can affect a product's operation and could result in serious personal injury.



\* Apply one drop of Loctite #242 or equivalent to cleaned parts. Allow 12 hours to set, if possible.

\*\* Install backup roller (Key 44) with the larger end facing out from tool.

\*\*\* Install feedwheel (Key 49) in noted rotational direction as shown by arrows.

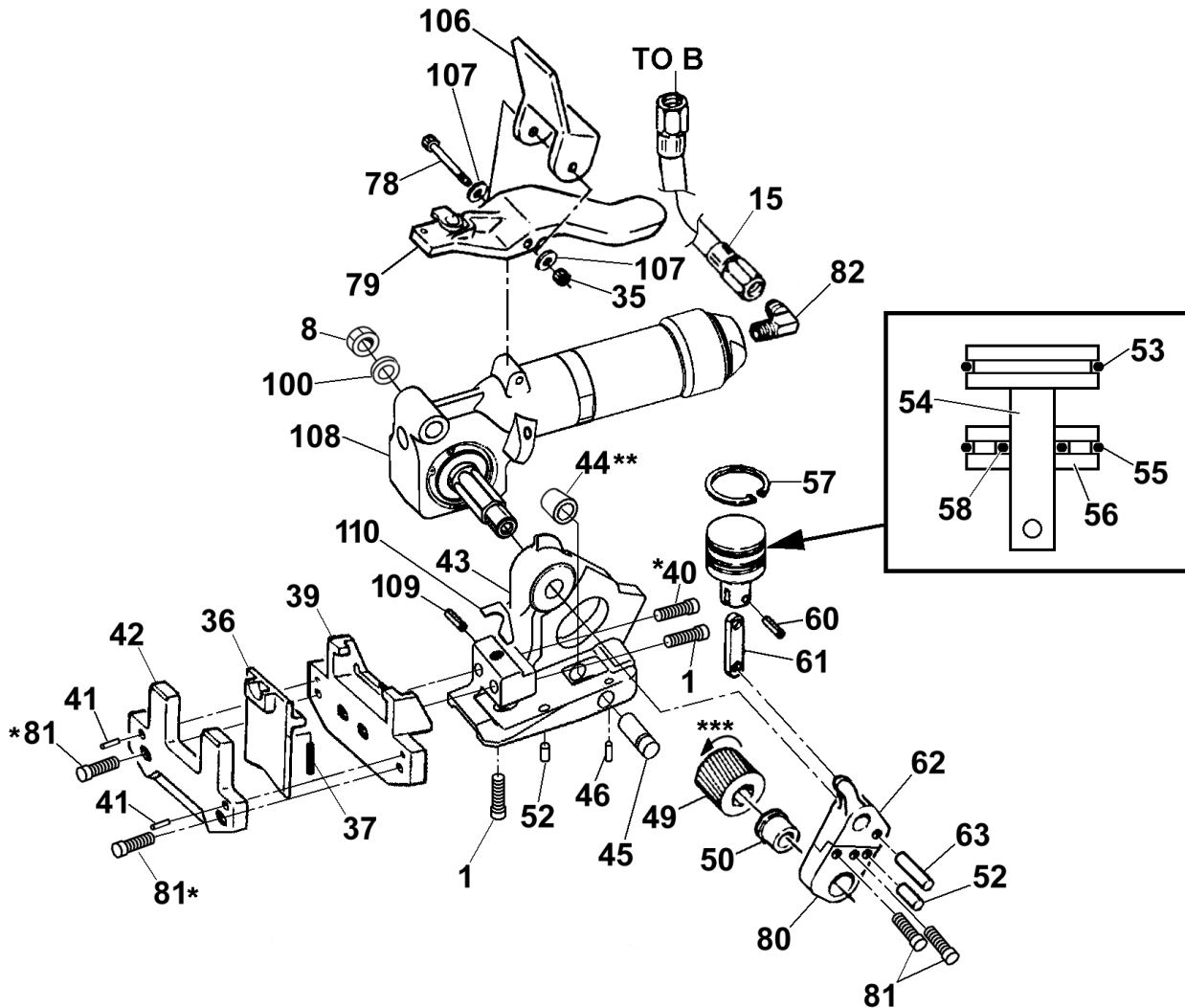

### PART REMOVAL, REPLACEMENT & ADJUSTMENT - FEEDWHEEL

To replace the feedwheel (Key 49), make sure the air supply has been disconnected from the tool before proceeding.

1. Remove the lower outer link by removing the two M6 mounting screws, and remove the feedwheel.
2. Feedwheel clearance should be checked after replacing any parts associated with the tensioning system. This clearance should be maintained to prevent the feedwheel from touching the backup roller. Feedwheel clearance should be adjusted to .001"-.007".
3. Turn the set screw (Key 4, Page 21) to adjust clearance.

## PARTS LIST , Continued

<u>KEY</u>	<u>QTY</u>	<u>PART NO.</u>	<u>DESCRIPTION</u>
51	1	<u>306512</u>	<u>Guard</u>
85	1	<u>424227</u>	<u>Rear side plate (PRHR-34)</u>
	1	<u>423417</u>	<u>Rear side plate (PRHR-114)</u>
86	2	<u>004127</u>	<u>Spacer</u>
88	1	<u>424228</u>	<u>Notcher (PRHR-34)</u>
	1	<u>306503</u>	<u>Notcher (PRHR-114)</u>
89	1	<u>423411</u>	<u>Ram</u>
90	2	<u>004134</u>	<u>Sealer link</u>
92	1	<u>004126</u>	<u>Ram pin</u>
93	2	<u>008507</u>	<u>Link pin</u>
94	4	<u>424233</u>	<u>Jaw (PRHR-34)</u>
	4	<u>423558</u>	<u>Jaw (PRHR-114)</u>
95	2	<u>008506</u>	<u>Jaw pin</u>
96	1	<u>424226</u>	<u>Front side plate (PRHR-34)</u>
	1	<u>423418</u>	<u>Front side plate (PRHR-114)</u>
97	2	<u>423557</u>	<u>Socket head shoulder screw, Dia 10 x M8 x 60</u>
98	1	<u>422837</u>	<u>Nylock nut, M8</u>
99	1	<u>423567</u>	<u>Flat head socket cap screw, M8 x 60</u>

- ! When ordering parts, please show tool model, part number and description.
- ! Wearing parts are usually limited to those underlined and should be stocked.
- ! Standard hardware may be obtained at any local hardware supply.



### NOTE:

To convert a standard PRHR-114 (0.031") to use 0.044" gauge strapping the following parts must be replaced/added. These conversion parts can be ordered together as PRHR-1444 Conversion Kit, Signode Part No. 424232.

<u>KEY</u>	<u>QTY</u>	<u>PART NO.</u>	<u>DESCRIPTION</u>	<u>STATUS</u>
88	1	306996	Notcher	Replace
110	1	423392	Shim	Add
112	1	424236	Nameplate	Replace

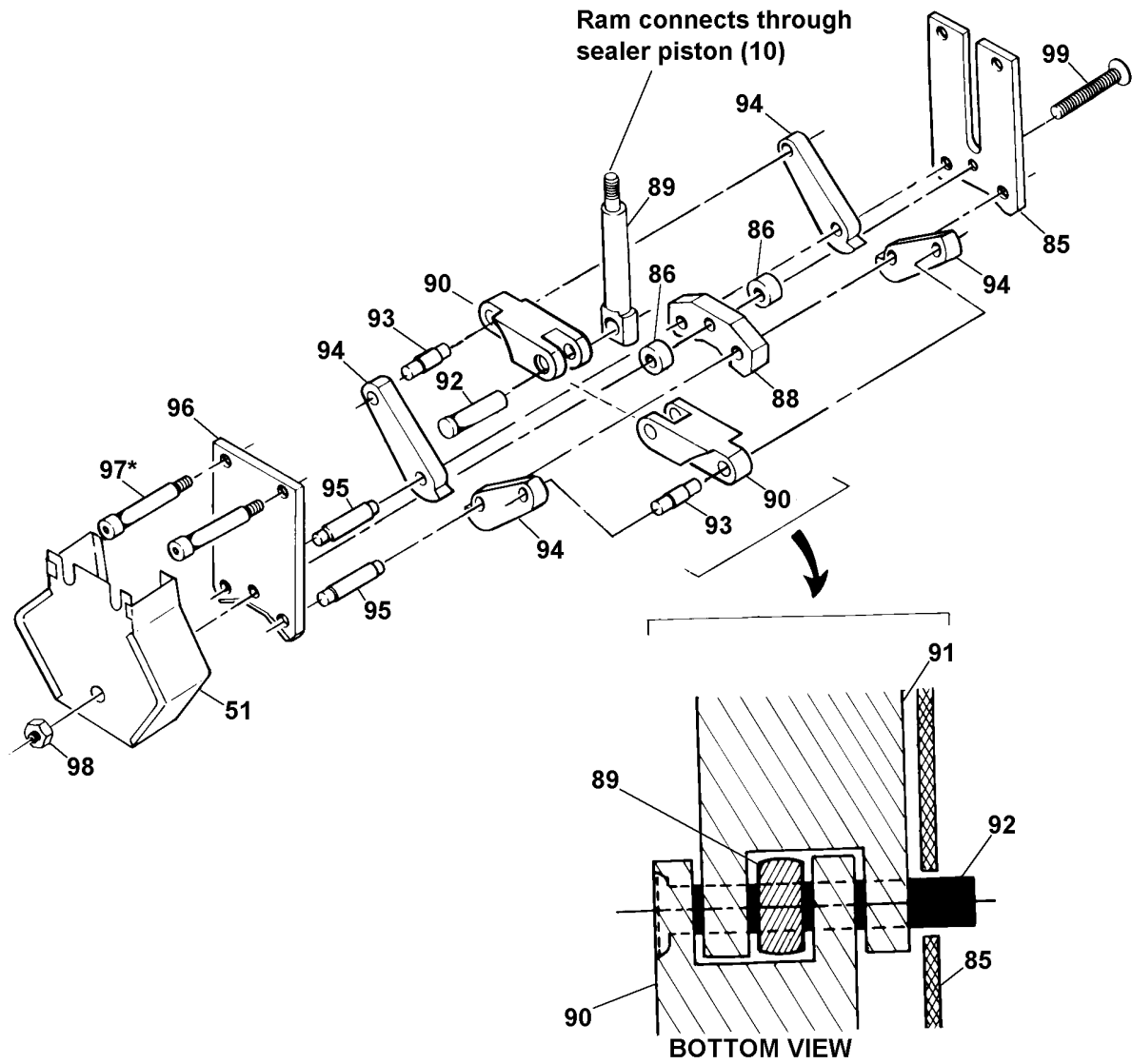

**\* Apply one drop of Loctite #242 sealant to cleaned parts. Allow 12 hours to set, if possible. Do not apply to small screws or close moving parts as the fluid spreads easily.**

## PARTS LIST, GEAR HOUSING

<u>KEY</u>	<u>QTY</u>	<u>PART NO</u>	<u>DESCRIPTION</u>
1	1	008781	Thrust washer
2	1	423402	Ring gear
4	1	423419	SHSS, M6 x 25
5	3	<u>008766</u>	<u>Idler gear</u>
7	1	<u>306389</u>	<u>Idler gear plate assy</u>
8	1	008756	Bearing, Fafnir #7203
9	1	008774	Key
10	1	423530	Worm
11	1	423421	Gear housing
12	1	008751	Needle bearing, Torrington #M781
13	1	008752	Truarc ring ,#500-62
14	1	423515	Bearing, Fafnir #B539DD
15	1	024038	Bearing, Fafnir #KP10A
16	1	423529	Worm Gear
17	1	423551	Feedwheel shaft
18	1	423396	Bearing support
19	1	250731	Truarc ring, N5000-185
20	1	256755	O ring, SAE 30
21	1	004165	O ring, SAE 210
22	1	423533	Thrust washer
23	1	423390	Air motor
24	1	280849	Hex nut, nylock, M6

- ! When ordering parts, please show tool model, part number and description.
- ! Recommended spare parts those underlined and should be stocked.
- ! Standard hardware may be obtained at any local hardware supply.

### NOTES:

1. Pack the gear housing (11) about 1/3 full with Non-Fluid Oil K#55 or equivalent.
2. When assembling the worm gear, the side stamped "T" or "BT" must face towards the back of the housing.
3. Bearing must be installed with wide shoulder away from worm.

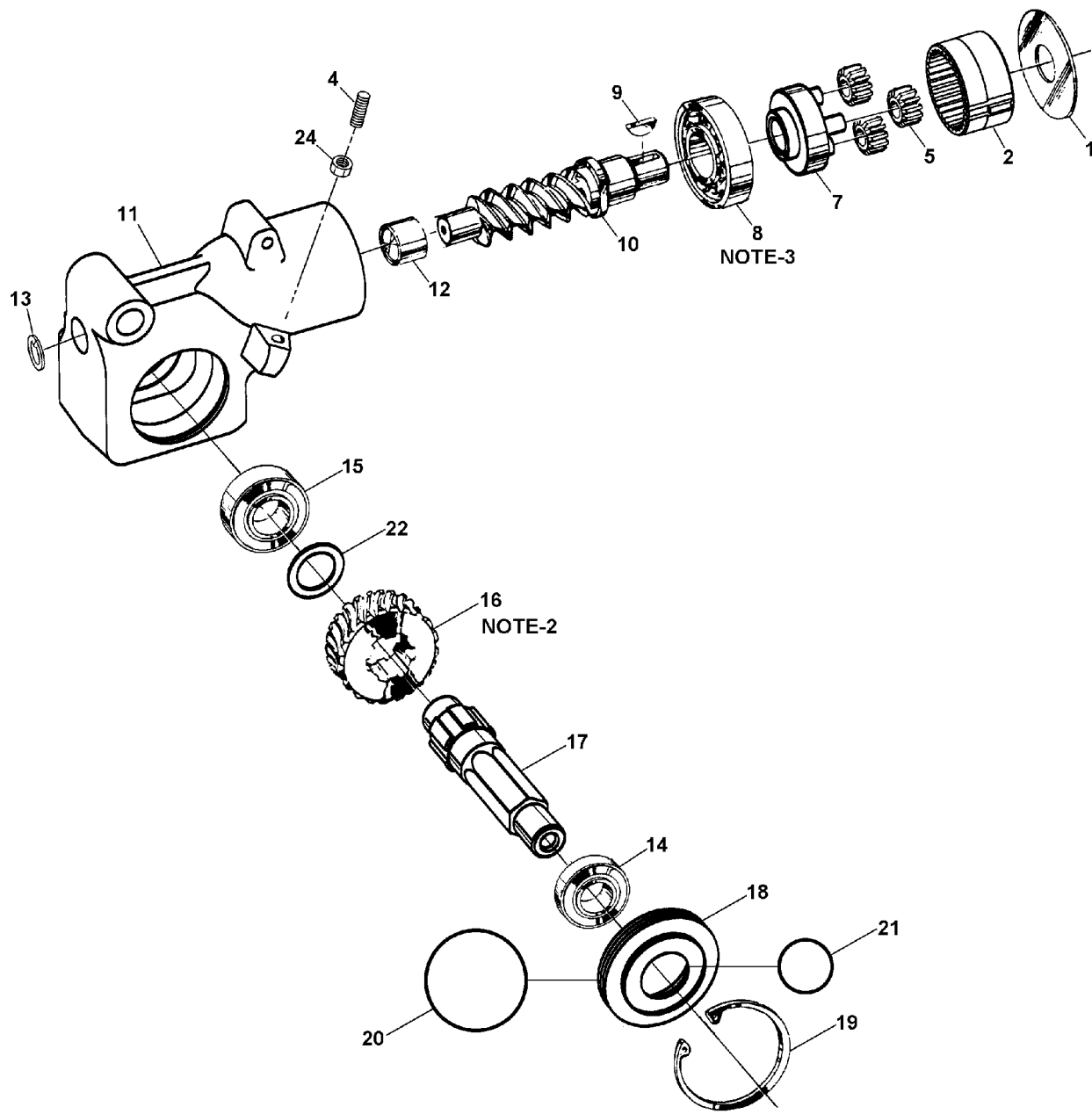

**⚠ WARNING**  
 Inspect all parts daily and replace them if they are worn or broken. Failure to do this can affect a product's operation and could result in serious personal injury.

**PARTS LIST, SIGNODE AIR MOTOR, PART NO. 423390**

<u>KEY</u>	<u>QTY</u>	<u>PART NO</u>	<u>DESCRIPTION</u>
1	1	024631	Filter assembly
9	1	423424	Motor housing assembly
12	1	423534	Deflector assembly
	1	161171	Deflector assembly (optional non-metallic)
13	1	024633	Ball bearing
14	1	024653	Back end plate
15	1	024652	Cylinder
16	1	423423	Rotor
17	5	024651	Vane
18	1	024602	Spacer
19	1	023510	Align pin
20	1	423794	Front end plate
21	1	023481	Ball bearing
22	1	023547	Ball bearing
24	1	423403	Idler carrier assembly
25	3	423060	Idler
26	1	423798	Ring gear
27	1	023558	Seal, Tros B-44-28-2
28	1	423404	Spacer
29	2	423793	Bevel spring washer
30	1	306612	Pin
31	1	423394	Gear housing

**NOTES**

1. Align pin (Key 19) and mark on motor housing as indicated.
2. Idler gears and bearings (except Key 13), are to be lubricated with Non-Fluid Oil #K55 or equivalent. Idler (Key 25) and vanes (Key 17) must soak in air line oil overnight before assembling air motor.
3. If the rear motor housing (Key 9) becomes loose, it must be retightened while the motor is running at 20 to 30 psig (1.6 to 2.0 Bar) air pressure. This will ensure proper alignment and rotor freedom.
4. Bevel spring washers (Key 29) must be assembled back to back with cupped shape outward ) ( .



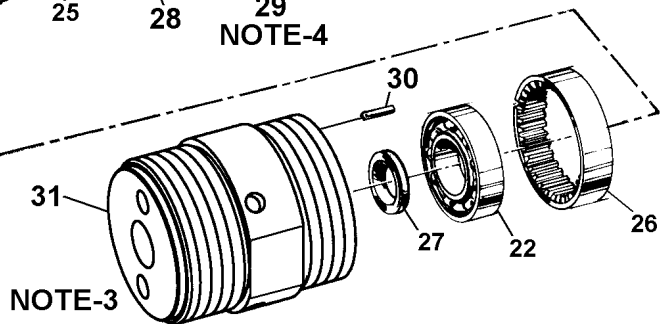
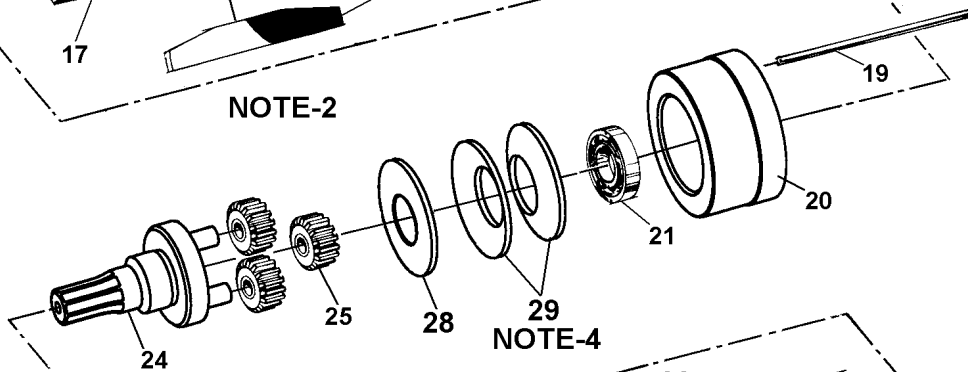
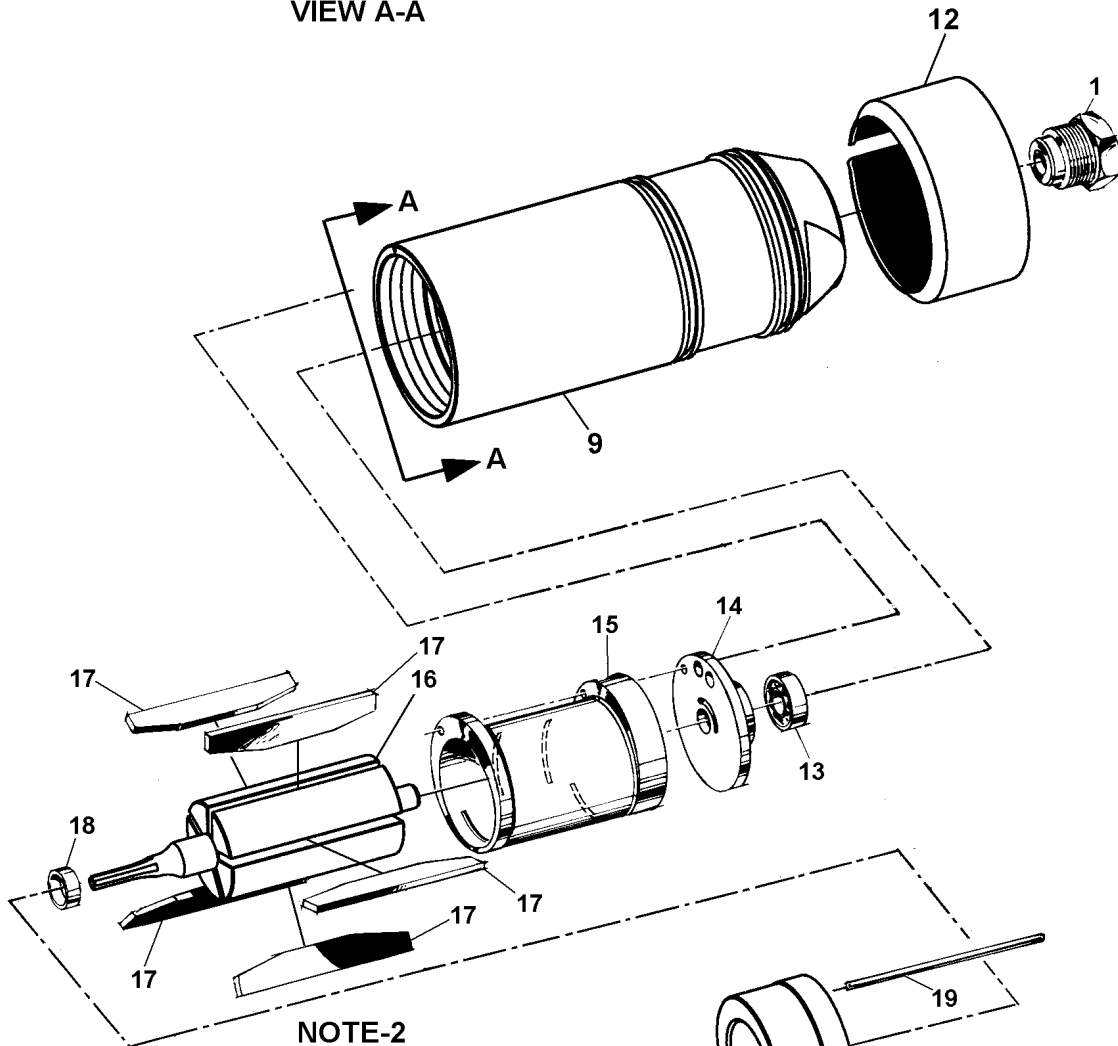
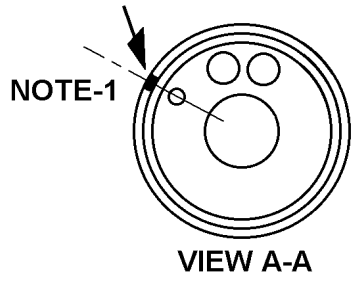









# SIGNODE®

## EU Declaration of Conformity

The Supply of Machinery (safety) Regulations  
1992 (S.I. 1992/3073)

It is hereby declared that the undermentioned machinery has been designed and constructed to comply with the health and safety requirements defined in EC Directive 89/392/EEC

Machine Supplier: Signode, Division of ITW Ltd.  
Queensway, Fforestfach  
Swansea SA5 4ED

Machine Description: PRH, PRH2, PRHR Series

Machine Type: Pneumatic Combination Hand Strapping tool.

Provisions with which machine complies:

89/392/EEC, 91/368/EEC

Harmonized EuroNorms with which machine complies:

EN 292:1, EN 292:2, EN 294, EN 349

Technical Standards with which machine complies:

NA

Signature:   
(Peter Oseland)

Date: 11 NOV 1994

## SIGNODE NEW TOOL WARRANTY

Signode Engineered Products Warrants that a new Signode strapping tool will operate per functional specifications for a period of sixty (60) days after the date of shipment to the owner's place of business. Normal wearing parts, as outlined in the Operation, Parts & Safety manual, are covered by a thirty (30) day warranty unless, in Signode's judgement, these parts have been subjected to abnormal or extreme usage. Signode's sole liability hereunder will be to repair or replace, without charge, F.O.B. Signode's Glenview, Illinois plant, any tool which proves to not operate per functional specifications within the stated period. Signode reserves the right to replace any tool which proves not to operate per functional specifications with a new or like-new tool of the same model if in Signode's judgement such replacement is appropriate. Any new replacement tool provided to an owner will carry a full sixty (60) day warranty. Any warranty repaired tool or like-new replacement tool will carry a warranty for the balance of the time remaining on the initial sixty (60) day warranty. This warranty will be extended to compensate for the time the tool is in Signode's possession for warranty repairs.

This warranty is void as to any tool which has been: (I) subjected to mis-use, misapplication, accident, damage, or repaired with other than genuine Signode replacement parts, (II) improperly maintained, or adjusted, or damaged in transit or handling; (III) used with improperly filtered, unlubricated air or improper strapping material, (IV) in Signode's opinion, altered or repaired in a way that affects or detracts from the performance of the tool.

**SIGNODE MAKES NO WARRANTY, EXPRESSED OR IMPLIED, RELATING TO MERCHANTABILITY, FITNESS OR OTHERWISE EXCEPT AS STATED ABOVE AND SIGNODE'S LIABILITY AS ASSUMED ABOVE IS IN LIEU OF ALL OTHERS ARISING OUT OF OR IN CONNECTION WITH THE USE AND PERFORMANCE OF THE TOOL. IT IS EXPRESSLY UNDERSTOOD THAT SIGNODE SHALL IN NO EVENT BE LIABLE FOR ANY INDIRECT OR CONSEQUENTIAL DAMAGES INCLUDING, BUT NOT LIMITED TO, DAMAGES WHICH MAY ARISE FROM LOSS OF ANTICIPATED PROFITS OR PRODUCTION, SPOILAGE OF MATERIALS, INCREASED COSTS OF OPERATION OR OTHERWISE.**

Considerable effort has been made to ensure that this product conforms to our high quality standards. However, should you experience any difficulties, please contact your Sales Representative providing samples and the manufacturing code specified on the tool.

Thank you for your help.

**SIGNODE ENGINEERED PRODUCTS**  
Hand Tool Division  
3620 W. Lake Avenue, Glenview, Illinois 60025

PART #	DESCRIPTION	AREA OF USE
<b>LUBRICANTS</b>		
177029	GEAR HOUSING GREASE	CLUTCH DRIVES, INTERNAL GEARS, GEAR SETS
422792	WHITE LUBRIPLATE GR-132 GREASE	PNEUMATIC PARTS, AIR CYLINDERS, AIR VALVES, O-RINGS
422793	BLACK LUBRIPLATE 3000W GREASE	MOVING INTERNAL PARTS, JAWS, LINKS
432322	EP ACCROLUBE GREASE	HIGH FRICTION CONTACT PARTS
008556	LS-1236 AIR LINE OIL	AIR MOTORS, AIR VALVES
<b>ADHESIVES</b>		
422794	LOCTITE #222, PURPLE	LOW STRENGTH, SCREWS 1/4" (6MM) OR SMALLER SIZES
422795	LOCTITE #242, BLUE	MEDIUM STRENGTH, SCREWS 5/16" (8MM) OR LARGER SIZES
422796	LOCTITE #271, RED	HIGH STRENGTH, SEMI-PERMANENT SCREW APPLICATION
422797	LOCTITE #609, GREEN	PERMANENT, CURVED SURFACE PART CONTACT
274111	LOCTITE #380, BLACK MAX	PERMANENT, FLAT SURFACE PART CONTACT
<b>CLEANING BRUSHES</b>		
023963	SMALL BRUSH	FEEDWHEEL & GRIPPER TEETH
269589	LARGE BRUSH	FEEDWHEEL & GRIPPER TEETH