

OPERATION, PARTS AND SAFETY MANUAL

It is the customer's responsibility to have all operators and servicemen read and understand this manual.

C-TYPE MANUAL SEALER

- C-3820 (Part No. 008600)
- C-1223 (Part No. 008605)
- C-5823 (Part No. 008610)
- C-3423 (Part No. 008615)

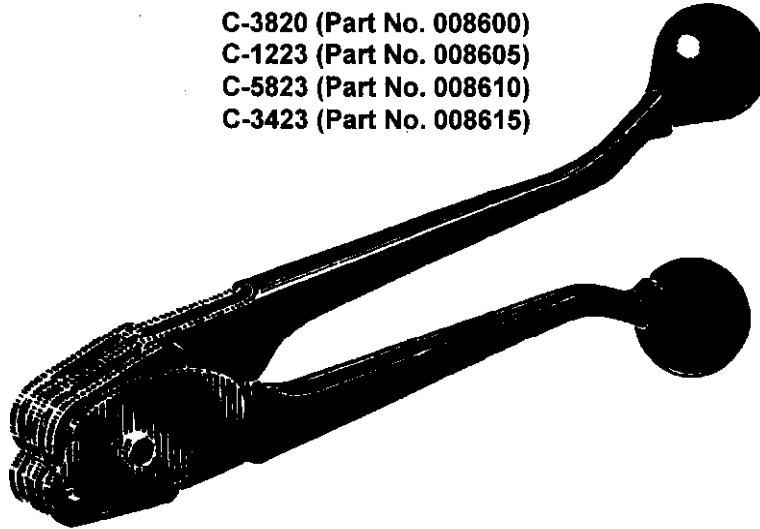

TOOL SPECIFICATIONS

TOOL MODEL	STRAP			SEALS	
	TYPE	WIDTH	THICKNESS	TYPE	REQUIRED SEALING OPERATIONS
C-3820	APEX	3/8" (9.5mm)	UP TO .020" (0.50mm)	38C	1
C-1223	APEX, MAGNUS	1/2" (12.7mm)	UP TO .023"(0.58mm)	12C	
C-5823	APEX, MAGNUS, STAINLESS STEEL	5/8" (15.8mm)		58C, STZ	
C-3423	APEX, MAGNUS	3/4" (19mm)		34C	

WARNING

Signode tools and machines are designed and warranted to work together with Signode strapping and seals. Use of non-Signode strap and seals and/or manufactured or specified replacement parts may result in strap breakage or joint separation while applying strapping to a load or during normal shipping and handling. This could result in severe personal injury.

IMPORTANT - DO NOT DESTROY THIS MANUAL. It is the customer's responsibility to have all operators and service personnel read and understand this manual. Contact your local Signode representative for additional copies of this manual.

⚠ WARNING

READ THESE INSTRUCTIONS CAREFULLY. FAILURE TO FOLLOW THESE INSTRUCTIONS CAN RESULT IN SERIOUS PERSONAL INJURY.

STRAP BREAKAGE HAZARD

Improper operation of the tool or sharp corners on the load can result in strap breakage during tensioning, which could result in the following:

- A sudden loss of balance causing you to fall.
- Both tool and strap flying violently towards your face.

Failure to place the strap properly around the load or an unstable or shifted load could result in a sudden loss of strap tension during tensioning. This could result in a sudden loss of balance causing you to fall.

- If the load corners are sharp use edge protectors.
- Positioning yourself in-line with the strap, during tensioning and sealing, can result in severe personal injury from flying strap or tool. When tensioning or sealing, position yourself to one side of the strap and keep all bystanders away.

TRAINING

This tool must not be used by persons not properly trained in its use. Be certain that you receive proper training from your employer. If you have any questions contact your Signode Representative.

EYE INJURY HAZARD

Failure to wear safety glasses with side shields can result in severe eye injury or blindness. Always wear safety glasses with side shields which conform to ANSI Standard Z87.1 or EN 166.



FALL HAZARD

Maintaining improper footing and/or balance when operating the tool can cause you to fall. Do not use the tool when you are in an awkward position.

CUT HAZARD

Handling strap or sharp parts could result in cut hands or fingers. Wear protective gloves.



TOOL CARE

- Inspect and clean the tool daily. Replace all worn or broken parts.
- Lubricate all moving parts weekly unless otherwise specified.

WORK AREAS

Keep work areas uncluttered and well lighted.

Use correct Signode products for your application. If you need help contact your Signode Representative.

Signode tools and machines are designed and warranted to work together with Signode strapping and seals. Use of non-Signode strap and seals and/or manufactured or specified replacement parts may result in strap breakage or joint separation while applying strapping to a load or during normal shipping and handling. This could result in severe personal injury.

JOINT FORMATION

- Before using this tool, read its Operation and Safety Instructions contains in this manual.
- This tool is a double notch type sealer.



NOTE: NOTCHES MUST BE EQUALLY SPACED ALONG THE ENTIRE LENGTH OF THE SEAL. FAILURE TO EQUALLY SPACE THE NOTCHES COULD RESULT IN STRAP SEPARATION. MORE THAN ONE SEAL MAY BE REQUIRED FOR CERTAIN APPLICATIONS - USE THE CORRECT NUMBER OF SEALS.

Each joint must be inspected to make certain it has the correct number of notches. A properly formed joint will appear as shown in the illustration. If the joint does not appear as shown, then the operator must proceed as follows:

1. Make certain that the tool's operating instructions are being followed before applying another strap.
2. Cut the strap off and apply a new strap and seal.
3. An improperly formed seal which does not have four (4) good notches, could result in strap separation. Before moving any package be certain that the seal is formed as shown. Inspect the joint to make certain it appears as shown in the illustration. If not, remove the broken strap and check the tool for worn or broken parts. Repair the tool for worn or broken parts. Repair the tool before applying another strap.

MOVING AND STACKING STRAPPED LOADS

Before moving or stacking any strapped load, follow all standard industry practices regarding safe material handling procedures.

CUTTING TENSIONED STRAP

Using claw hammers, crowbars, chisels, axes or similar tools will cause tensioned strap to fly apart with hazardous force. Use only cutters designed for cutting strap. Read the instructions in the cutter's manual for proper procedures in cutting strap. Before using any Signode product read its Operation and Safety Manual.

OPERATING INSTRUCTIONS

⚠ WARNING

Wear safety glasses which conform to ANSI Standard Z87.1 or EN 166.

Stand to one side of the strap while tensioning. Make sure all bystanders are clear before proceeding.

Failure to follow the above could result in serious personal injury.

1. Fully open the sealer handles and center the open jaws on the seal.

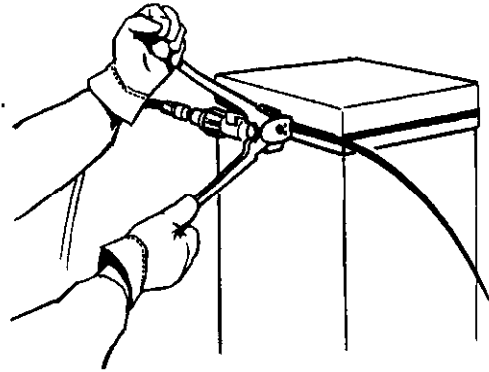

2. Bring the sealer handles completely together to assure a proper notch.

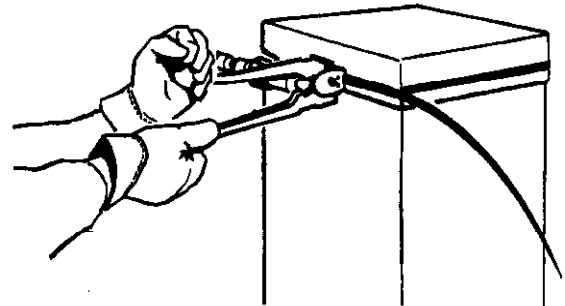

3. Remove the sealer and bend the loose strap sharply back on the seal. Several additional bends will result in a clean strap break-off. If the width and gauge of the strap being used will not allow it to be bent, cut the strap supply as close to the seal as possible using an approved strap cutter.
4. To avoid contact with the sharp end of the strap, retract strap end back into the strap dispenser.

PARTS LIST

KEY	QTY.	PART NO. C-3820	PART NO. C-1223	PART NO. C-5823	PART NO. C-3423	DESCRIPTION
1	1	<u>004526</u>	<u>004526</u>	<u>004526</u>	<u>004526</u>	Flexloc nut, thin 1/4-28
2	2	<u>008601</u>	<u>008609</u>	<u>008618</u>	<u>008623</u>	Side plate
*3	8	<u>008603</u>	<u>008608</u>	<u>008616</u>	<u>008616</u>	Jaw
4	2	<u>008606</u>	<u>008606</u>	--	--	Notcher pin
4A	4	--	--	<u>008612</u>	<u>008612</u>	Notcher pin
5	2	<u>008602</u>	<u>008676</u>	<u>008617</u>	<u>008632</u>	Notcher
6	2	<u>008604</u>	<u>008604</u>	<u>008614</u>	<u>008614</u>	Jaw pin
7	1	<u>008626</u>	<u>008626</u>	<u>008611</u>	<u>008611</u>	Guide pin
8	2	<u>004874</u>	<u>004874</u>	--	--	Toggle pin
9	1	<u>007492</u>	<u>007492</u>	<u>007492</u>	<u>007492</u>	Spacer washer, 1/4 std. SAE
10	1	<u>003943</u>	<u>003943</u>	--	--	Hex head cap screw, 1/4-28 x 1 1/4
	1	--	--	<u>003726</u>	<u>003726</u>	Hex head cap screw, 1/4-28 x 1 3/8
11	2	<u>008648</u>	<u>008648</u>	<u>008648</u>	<u>008648</u>	Knob, (press-on)
12	1	<u>003133</u>	<u>003133</u>	<u>003133</u>	<u>003133</u>	Caution plate
13	2	<u>008660</u>	<u>008660</u>	<u>008660</u>	<u>008660</u>	Sealer handle assembly

NOTES:

1. When ordering parts, please show tool model, part number and name.
2. All recommended spare parts are underlined and should be stocked.
3. Standard hardware parts may be obtained from local hardware suppliers.

WARNING

Inspect all parts daily and replace them if they are worn or broken. Failure to do this can affect a product's operation and could result in serious personal injury.

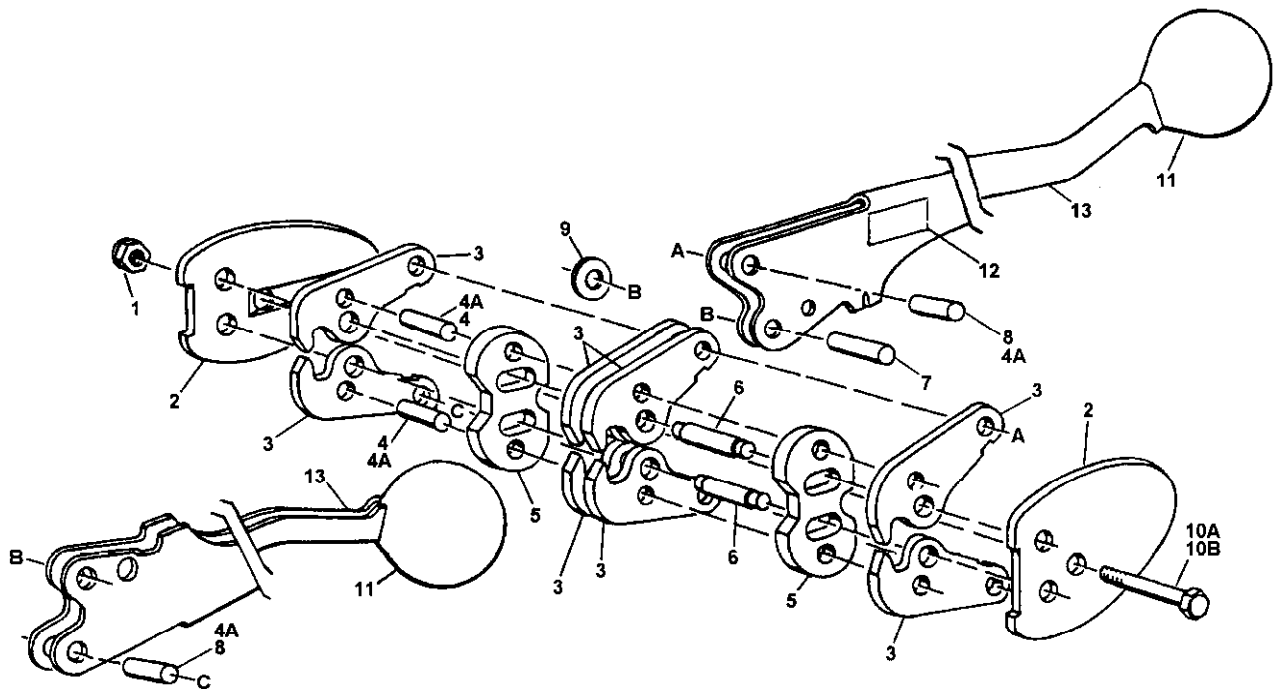

MAINTENANCE

1. Inspect tool daily for worn or broken parts and replace if necessary.
2. Clean tool and apply light machine oil to all moving parts - weekly.