



**READ ALL SAFETY INSTRUCTIONS BEFORE OPERATING THIS SIGNODE PRODUCT**

# **OPERATION, PARTS AND SAFETY MANUAL**

*It is the customer's responsibility to have all operators and servicemen read and understand this manual.*

## **PH-2 MANUAL STRAP TENSIONER**

Part No. 010065

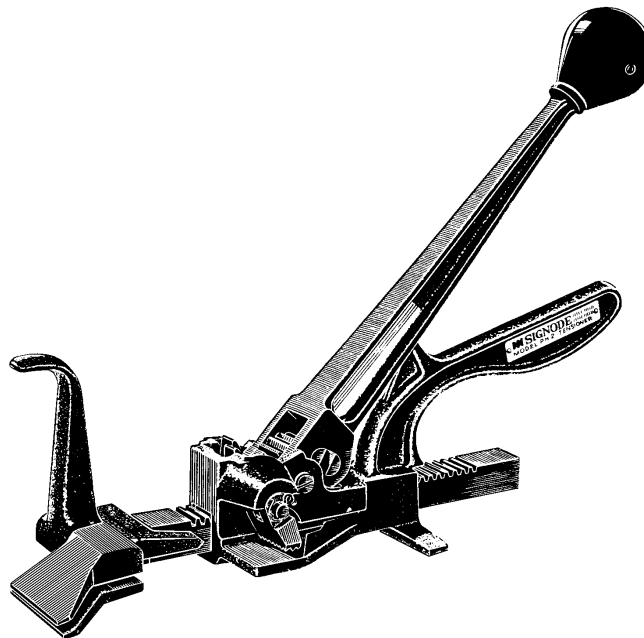

### **TOOL SPECIFICATIONS**

<b>STRAP TYPE</b>	<b>WIDTH</b>	<b>THICKNESS</b>
Apex & Magnus	3/4"(19.0mm) to 1-1/4" (31.7mm)	.020"(0.50mm) to .035"(0.88mm)



**IMPORTANT - DO NOT DESTROY THIS MANUAL.** It is the customer's responsibility to have all operators and service personnel read and understand this manual. Contact your local Signode representative for additional copies of this manual.

© Copyright 2000, Signode 186009 Rev. 1/2000

# **WARNING**

**READ THESE INSTRUCTIONS CAREFULLY. FAILURE TO FOLLOW THESE INSTRUCTIONS CAN RESULT IN SERIOUS PERSONAL INJURY.**

## **STRAP BREAKAGE HAZARD**

Improper operation of the tool or sharp corners on the load can result in strap breakage during tensioning, which could result in the following:

- A sudden loss of balance causing you to fall.
- Both tool and strap flying violently towards your face.

Failure to place the strap properly around the load or an unstable or shifted load could result in a sudden loss of strap tension during tensioning. This could result in a sudden loss of balance causing you to fall.

- If the load corners are sharp use edge protectors.
- Positioning yourself in-line with the strap, during tensioning and sealing, can result in severe personal injury from flying strap or tool. When tensioning or sealing, position yourself to one side of the strap and keep all bystanders away.

## **TRAINING**

This tool must not be used by persons not properly trained in its use. Be certain that you receive proper training from your employer. If you have any questions contact your Signode Representative.

## **EYE INJURY HAZARD**

Failure to wear safety glasses with side shields can result in severe eye injury or blindness. Always wear safety glasses with side shields which conform to ANSI Standard Z87.1 or EN 166.



## **FALL HAZARD**

Maintaining improper footing and/or balance when operating the tool can cause you to fall. Do not use the tool when you are in an awkward position.

## **CUT HAZARD**

Handling strap or sharp parts could result in cut hands or fingers. Wear protective gloves.



## **TOOL CARE**

- Inspect and clean the tool daily. Replace all worn or broken parts.
- Lubricate all moving parts weekly unless otherwise specified.

## **WORK AREAS**

Keep work areas uncluttered and well lighted.

Use correct Signode products for your application. If you need help contact your Signode Representative.

Signode tools and machines are designed and warranted to work together with Signode strapping and seals. Use of non-Signode strap and seals and/or manufactured or specified replacement parts may result in strap breakage or joint separation while applying strapping to a load or during normal shipping and handling. This could result in severe personal injury.

## **SAFETY PROCEDURES FOR TOOL OPERATION**

- Before using this tool, read its Operation and Safety Instructions contains in this manual.
- Tuck strap end back into the dispenser when not in use.

## **JOINT FORMATION**

Never handle or ship any load with improperly formed joints. Misformed joints may not secure the load and could cause serious injury. Follow the joint inspection procedures in each sealers manual.

## **MOVING AND STACKING STRAPPED LOADS**

Before moving or stacking any strapped load, follow all standard industry practices regarding safe material handling procedures.

## **CUTTING TENSIONED STRAP**

Using claw hammers, crowbars, chisels, axes or simialr tools will cause tensioned strap to fly apart with hazardous force. Use only cutters designed for cutting strap. Read the instructions in the cutter's manual for proper procedures in cutting strap. Before using any Signode product read its Operation and Safety Manual.

# **WARNING**

Signode tools and machines are designed and warranted to work together with Signode strapping and seals. Use of non-Signode strap and seals and/or manufactured or specified replacement parts may result in strap breakage or joint separation while applying strapping to a load or during normal shipping and handling. This could result in severe personal injury.

## OPERATING INSTRUCTIONS

# ⚠ WARNING

- Wear safety glasses which conform to ANSI Standard Z87.1 or EN 166.
- Stand to one side of the strap while tensioning. Make sure all bystanders are clear before proceeding.
- Failure to follow the above could result in serious personal injury.

1. Encircle the bundle with the strap threaded through a seal as shown. Be sure the end of the lower strap is bent back beneath the seal.

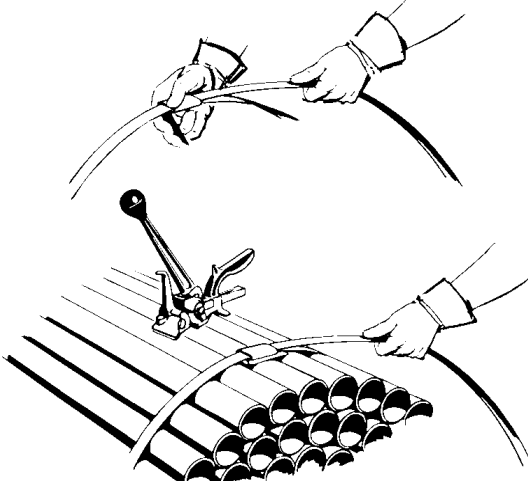

2. Squeeze the two handles as shown. This will open the gripper to allow the upper strap to be inserted through the slotted nose and under the gripper. Pull strap with your left hand to remove slack.

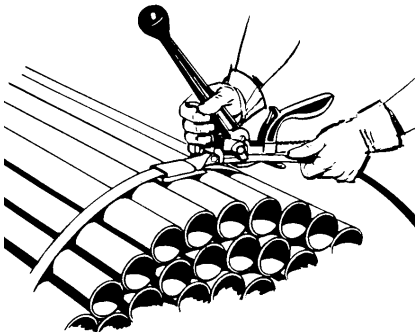

3. While standing to one side of the strap line, apply final tension to the strap.

If insufficient tension is attained on the first full travel of the rack, hold the strap with your left hand and slide the gripper housing forward for a new "bite".

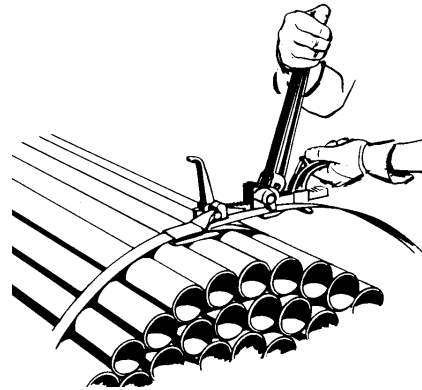

4. Fully notch the seal. If using a single notch sealer, be sure to complete the sealing operation twice on seals requiring two notches.

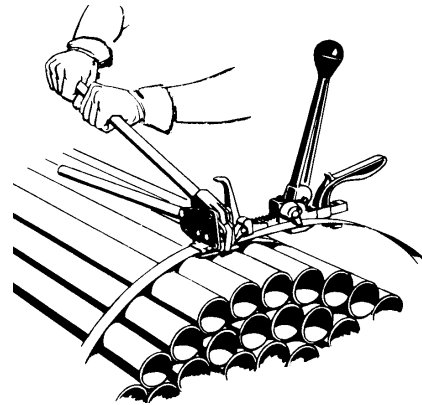

5. Break the strap off over the end of the seal with the nose of the stretcher. Repeat the bending motion if necessary. Do not release tension before break-off and do not tip the stretcher beyond a straight up and down position.

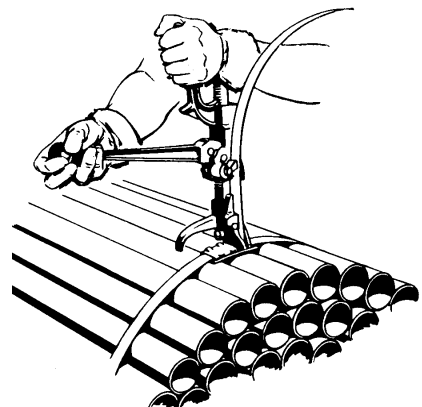

**PARTS LIST, PH-2 (010065)**

<u>KEY</u>	<u>QTY.</u>	<u>PART#</u>	<u>DESCRIPTION</u>
1	1	423277	Breaking nose base
2	1	010019	Roll pin, 1/4 dia. x 1 1/8 long
7	1	010005	Rack
8	1	010043	Gripper pin
9	1	001621	Cotter pin, 3/32 dia. x 1/2 long
10	1	003868	Flexloc nut, 3/8-24 thin
11	1	010011	Gripper
12	1	010021	Handle pivot pin
13	1	010004	Gripper spring
14	1	010016	Gear
15	2	010008	Pawl spring
16	1	010007	Long Pawl
17	1	010014	Ratchet spring
18	1	010006	Short pawl
19	1	010013	Pawl
20	1	010053	Handle
21	1	010054	Handle knob
22	1	010057	Roll pin, 1/4dia. x 1 3/4 long
23	1	010055	Long rack (optional)
24	1	010066	Slide housing
25	1	003133	Warning label
26	1	002485	Nameplate
27	2	002163	Drive screw

**⚠ WARNING**

Inspect all parts daily and replace them if they are worn or broken. Failure to do this can affect a product's operation and could result in serious personal injury.

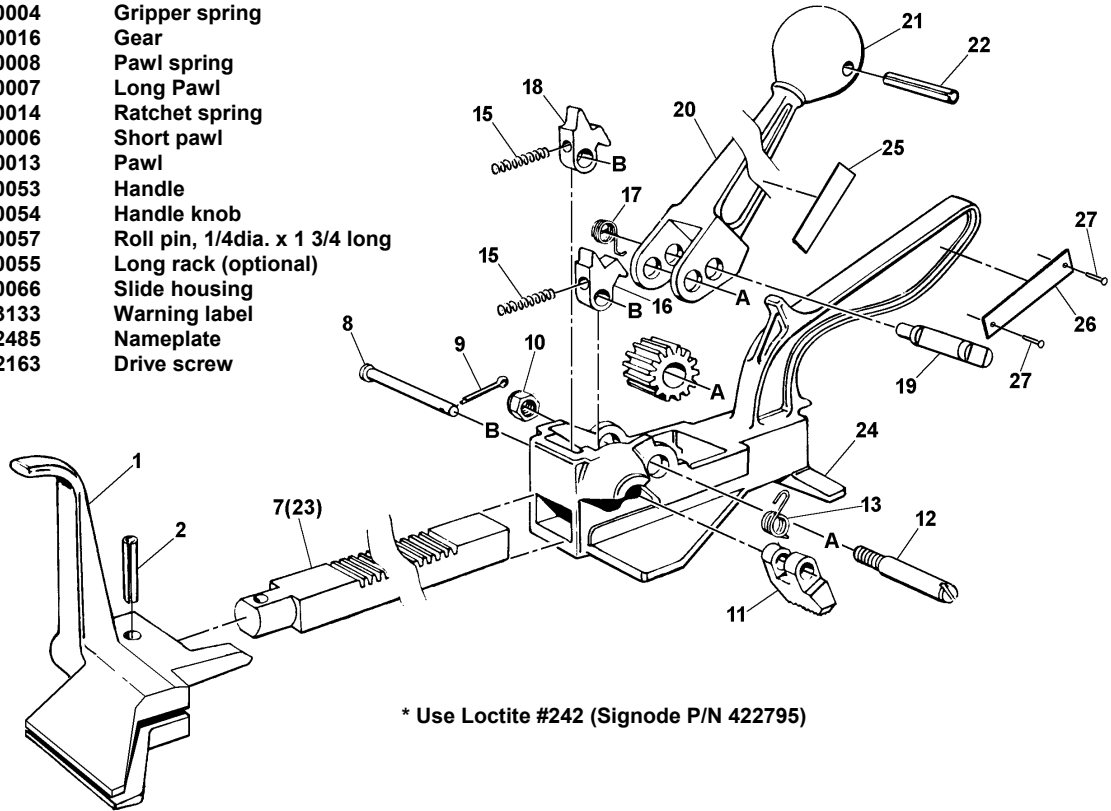

\* Use Loctite #242 (Signode P/N 422795)

**NOTES:**

1. When ordering parts, please show tool model, part number and name.
2. All recommended spare parts are underlined and should be stocked.
3. Standard hardware parts may be obtained from local hardware suppliers.

**MAINTENANCE**

Clean and apply a light weight machine oil to all moving parts on a weekly basis. Clean the gripper daily with a wire brush. Debris accumulated in the teeth of the gripper must be removed with a small wire brush. A need to clean the teeth will become apparent when the gripper skids on the strap during tensioning.